

# Välkomna!

**EFFEKT**  **DALARNA**  
Samverkan för energiplanering



Länsstyrelsen  
Dalarnas län

Kan ditt företag/organisation betala  
1000 kronor per person, i en frivillig deltagaravgift  
för att bidra till ukrainska ungdomars  
sommarläger i Dalarna?

Om ja, skriv kontaktperson under  
organisationens namn på listan.



**TACK!**

# Inledning

Helena Höij  
Landshövning i Dalarnas län

# Kunskapshöjning om datahallar

Tor Björn Minde  
Director,

Head of RISE ICE Data center system research

# What is a (AI) datacenter, why do we need them and what are the energy implications?

Tor Björn Minde  
RISE – Research Institutes of Sweden

Region Dalarna, April 27, 2026



# 4,212

SEK million, net sales

Operating results: 74 SEK million

Operating margin: 1,8%

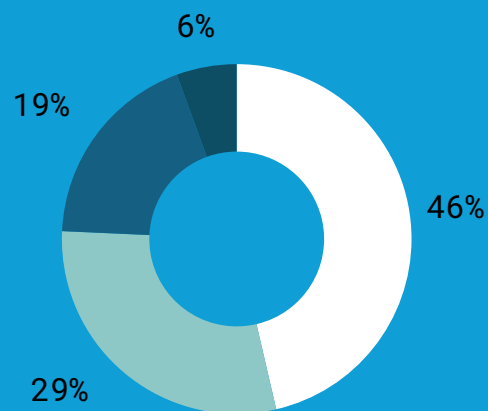

Distribution of net sales

Business sector	1,953 MSEK
Public funds	1,236 MSEK
State funds	789 MSEK
EU funds	234 MSEK

Approx.

# 3,300

employees

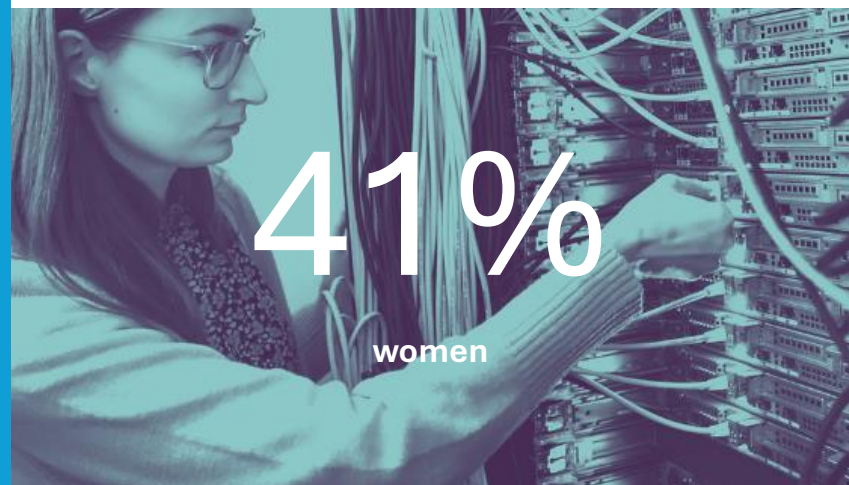

# 41%

women

# 130+

Testbeds and demonstration environments

We are represented at

# 35

locations around Sweden



# 77

(2024)

Customer Satisfaction Index



# RISE ICE Data Center

A full-scale research datacenter and test environment with the objective to increase knowledge and strengthen the global AI & Data Center ecosystems

- 40+ projects, from the ground to the cloud
- 30+ employees
- 4+ MEUR turnover
- Established 2016
- 100+ project partners

Partners: Ericsson, ABB, Vattenfall, Meta, LTU, Region North, Vertiv, BP Castrol, Alfa Laval, Grundfos, Google, Intel, Telia, Submer



# ICE data center test environment



Module 1 & 2 Research  
Compute clusters



Module 3 OCP Lab, Climate box  
and Heat box



Module 4  
Facility hardware test lab



Edge, wind tunnels and  
liquid cooling test beds

## ICE Data center lab

- 1600 sqm lab 2,5MW+
- Heat loads, server emulators & 2000 servers
- Open-source based data collection

## ICE Connect

- OCP, high-end CPU/GPU physical servers, 10+ petabyte storage,
- 240+ GPUs, 15 pflops
- OpenStack, OpenNebula Kubernetes clusters
- 5G Edge nodes

# Current Official Partners in the Partner Program

Premium partners:



Collaborators:



Academic:



# Industrialization – Innovation based on energy



# New-Industrialization – Innovation based on energy



# How does the internet work?

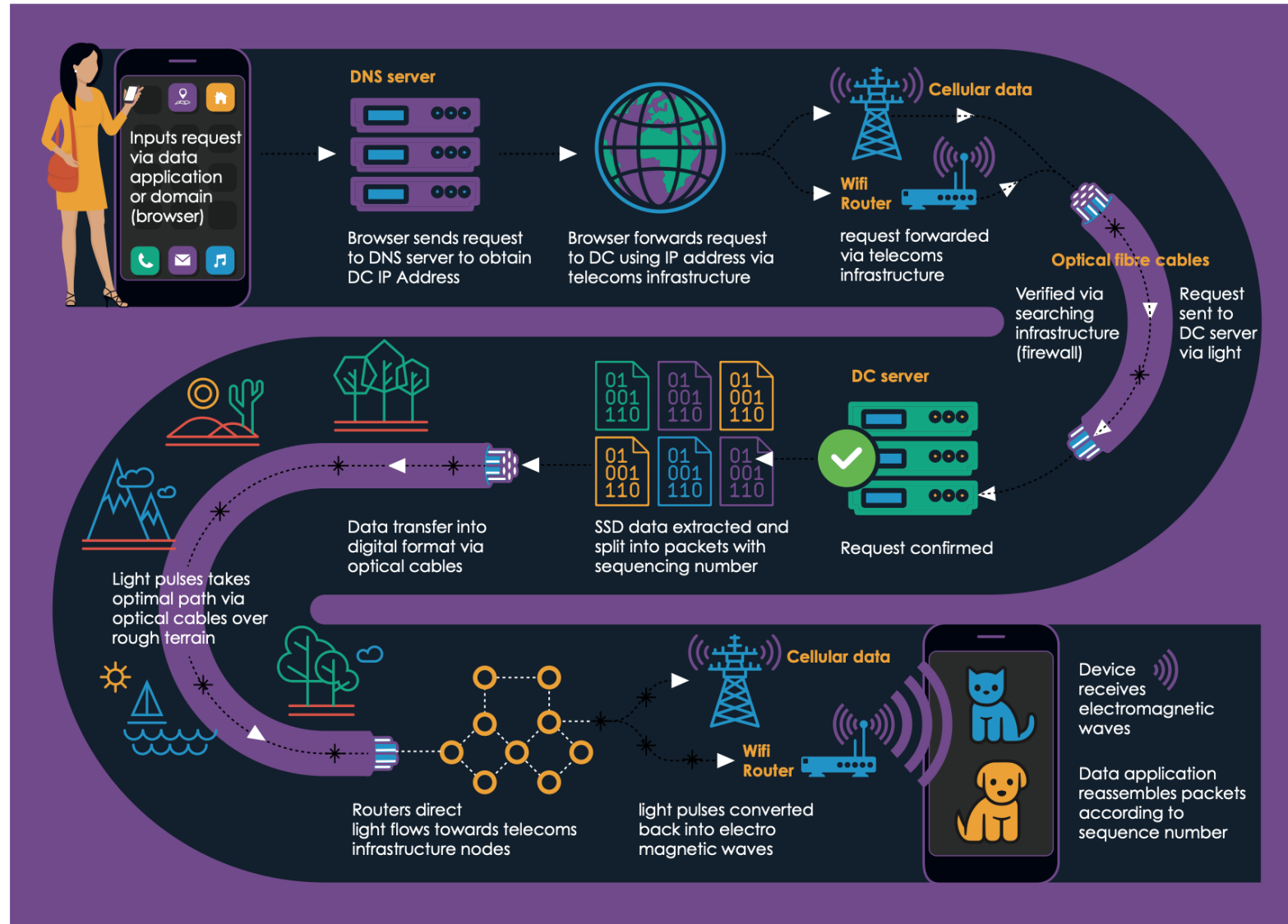

# Digital infrastructures are used from the early morning...

**At home, breakfast**

*Time to wake up...*

**06:45** **Woken by radio alarm**  
Some alarms are auto-corrected by GPS satellite signal and managed through a secure data centre.

**06:46** **Switch on lights**  
Your electricity account is located in a data centre, with payments made through several data centres.

**06:50** **Use toilet**  
Your water account is in a data centre. Metered consumption is reported over a mobile-phone network via a data centre.

**06:55** **Put kettle on**  
Your instantaneous energy use is not currently monitored (smart metering and smart grid developments will change that) but electricity accounts are managed in data centres.

**07:00** **Put the cat out**  
As a responsible owner your pedigree moggie is chipped and registered with the vet. Many vets use a cloud service for record keeping and billing.

**07:01** **Check SMS rail alerts**  
Your mobile provider uses a data centre network for messaging, routing and billing. Network Rail uses a data centre to manage rail information.

*Train's late again!*

**07:02** **Station closed, Google alternatives**  
A Google search involves up to five data centres: your ISP, Google's UK gateway, three Google Hadoop search engines in Belgium, NL and Finland.

**07:10** **Eat breakfast**  
You shop in a supermarket that has a loyalty card system; your breakfast foibles are tracked and stored in a data centre.

Source: How the internet works (TechUK 2020)

# ...and it continuous all day long....

**At work**

*Another day in paradise!*

**08:50** **Swipe card to enter office**  
Swipe card is locally controlled but the system watchdog records movements and uploads the batch files to the remote security company's data centre

**08:52** **Make coffee**  
Electricity use not monitored directly - yet - but billing is enabled by a data centre

**09:00** **Log on to system**  
Log-in monitored by ISP for cost allocation to department and saved to file. Access may just be managed by your company's local server, but likely to be backed up in a data centre

**09:05** **Use email**  
Your ISP data centre for traffic and your company email server in its own micro-data centre

**09:20** **Book business trip**  
Your ISP data centre and several third-party service providers, e.g. Laterooms.co.uk, Expedia.com, BA.com, EasyJet.com etc. Credit card data centre and system authorisation

**10:15** **Conduct online research**  
Research involves multiple data centres including your ISP, Google and onto global digital libraries like Carnegie Mellon et al

*Every data centre helps*

**12:30** **Use cashpoint**  
Electronic transactions are enabled by your bank's data centre

**12:45** **Buy lunch in Tesco**  
Tesco didn't become the No. 1 grocery retailer in the UK by chance - they knew how to use ICT and customer data. They manage, process and store data in data centres

**12:50** **Receive text, text back**  
Data centre tracks which cell you are located in. Text goes back through network and probably crosses over into another operator's data centre network

**13:00** **Use Barclays bike**  
Hire and deposit transaction logged on bike data centre and credit card transaction to bank data centre

**13:30** **Teleconference over Skype**  
Skype service runs via ISP to Skype's collocated data centre resource

**17:00** **Receive annoying spam texts**  
Spam texts are generated from databases in numerous data centres

# Digital infrastructure – network view

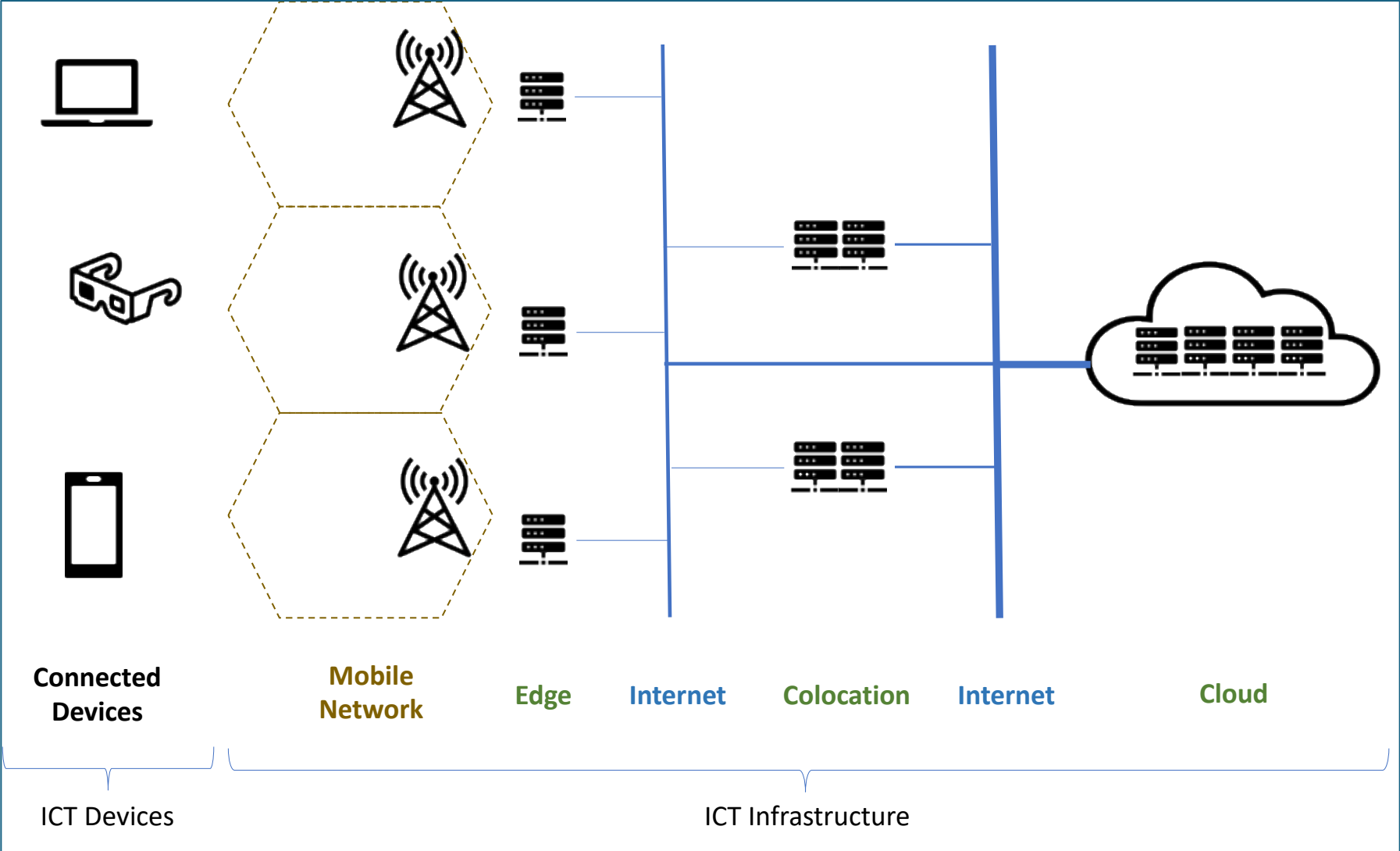

Source: Data center energy use (RISE 2023).

# Digital infrastructure – including data centers

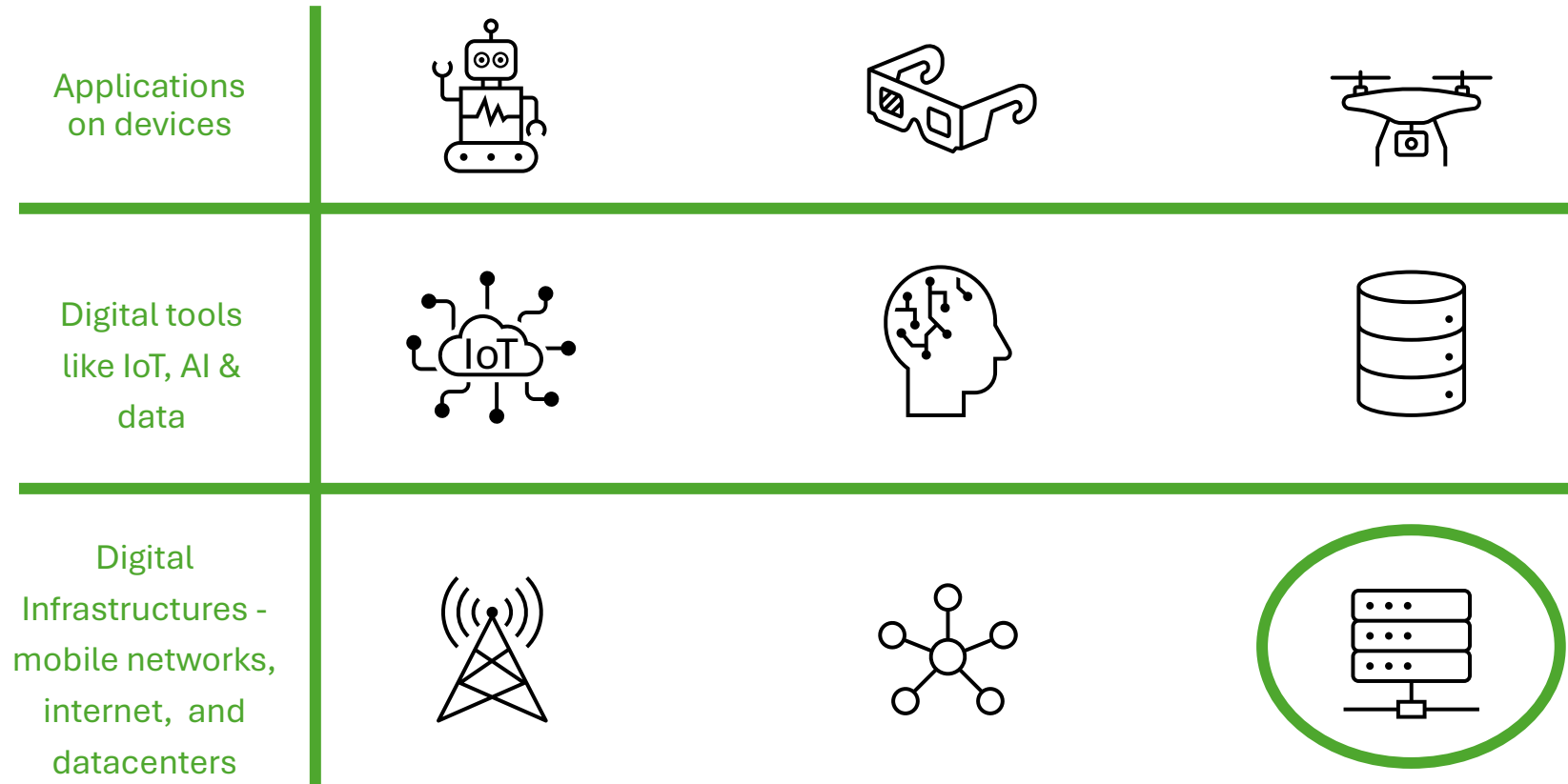

# Data center infrastructure

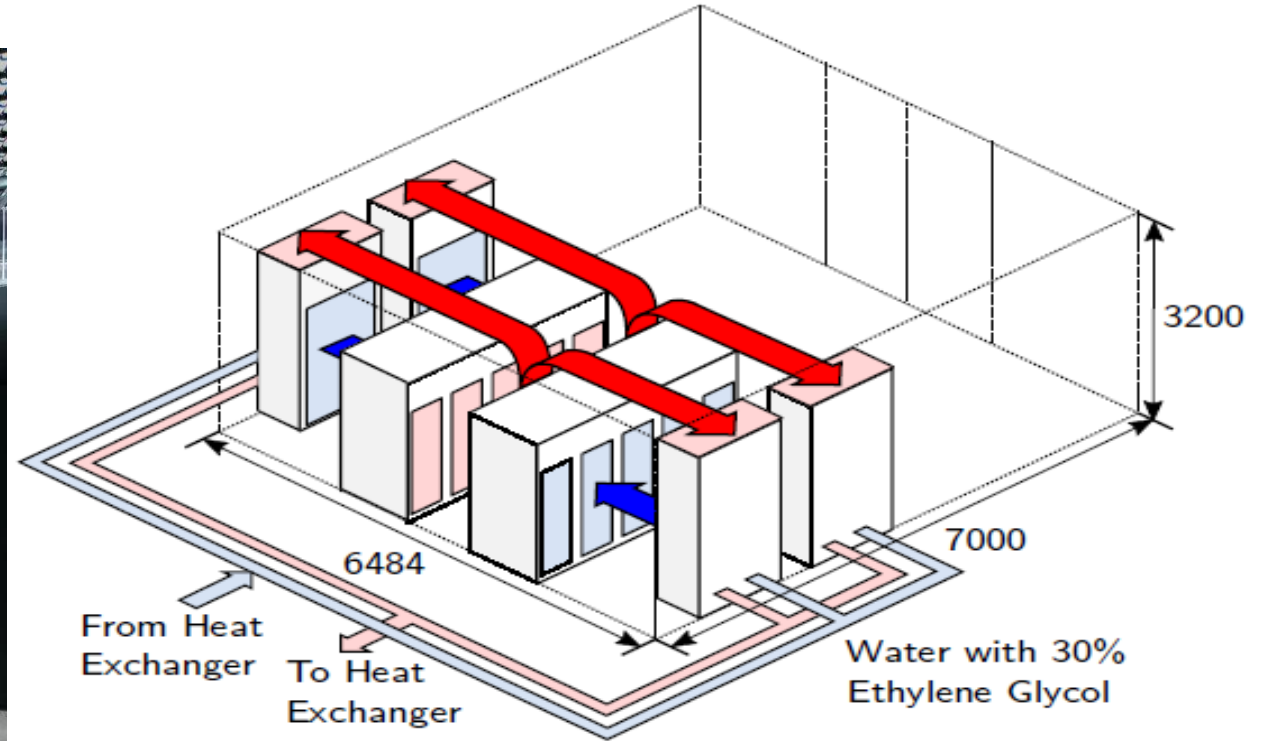

**Data centers are fundamental infrastructures for the society like roads.  
Data centers are central in the digitalization and for the ongoing green transformation**

# Data center – Large scale IT infrastructure

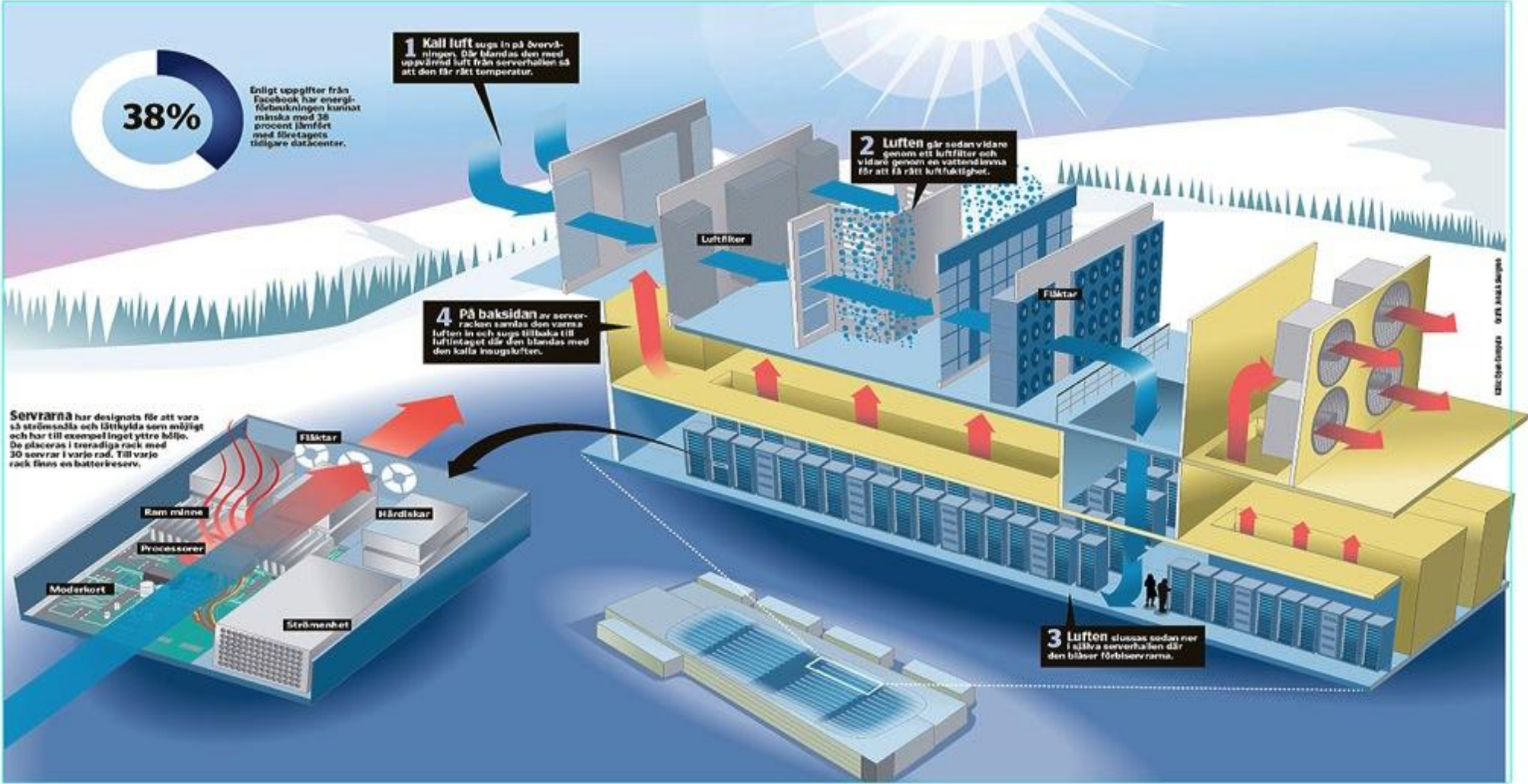

# Simplified data center infrastructure

100 MW Air cooled DC

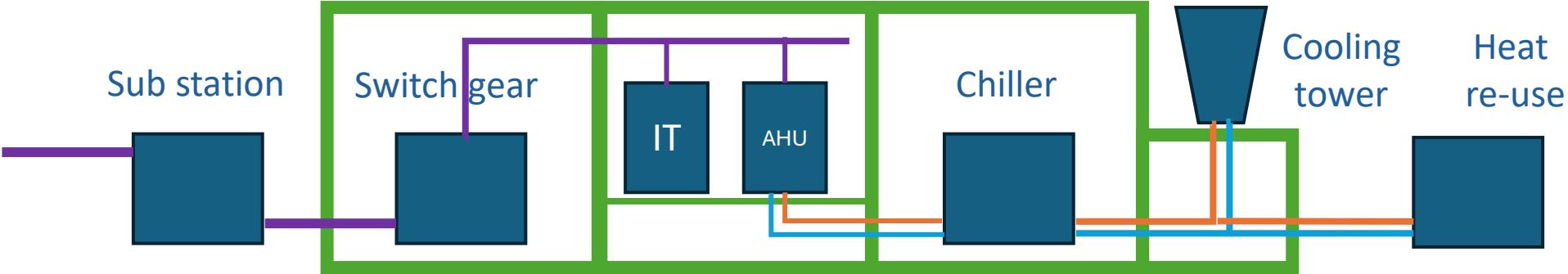

1 GW Liquid cooled DC

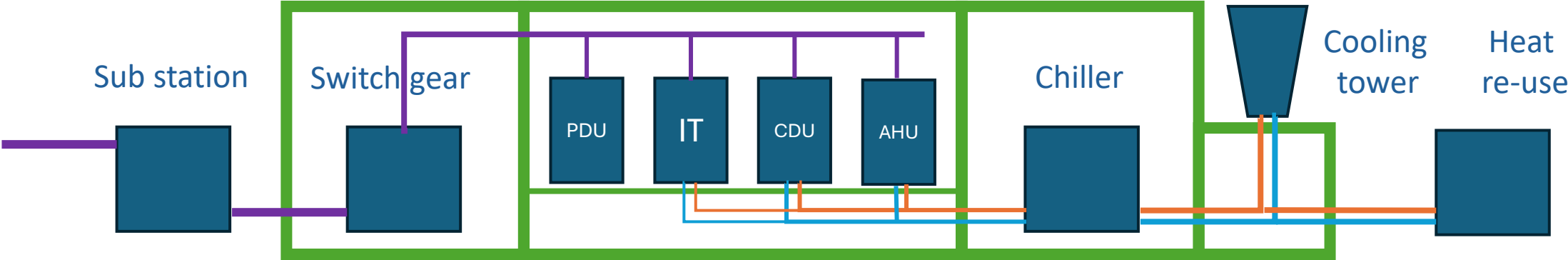

Source: RISE 2025

# Data center energy use breakdown

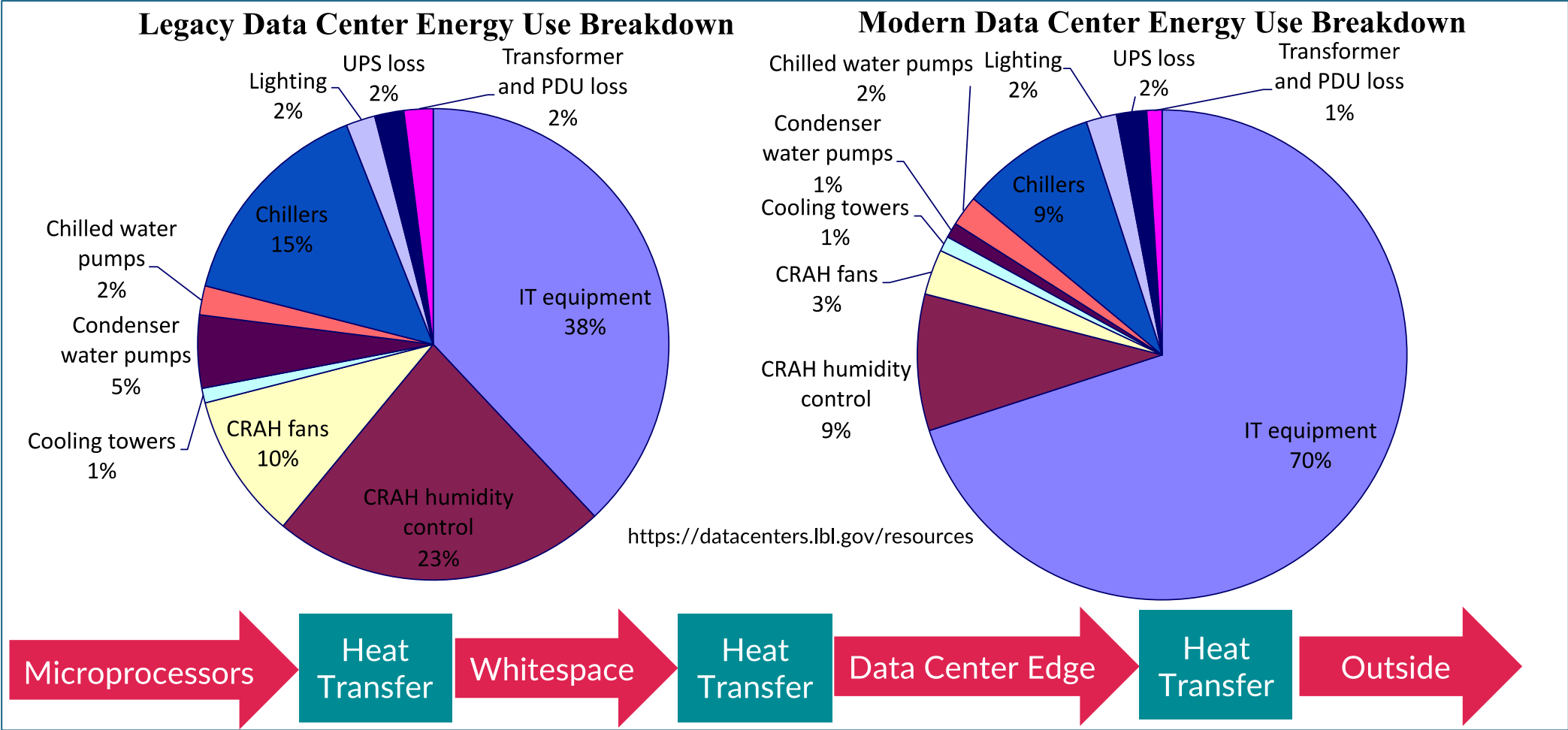

Source: Center of Expertise for energy efficient in data centers (2022)



# Size versus type of data centers

	Own Internal		Service provider/Integrator			Commercial		Hyperscale
	On-premise		Far edge	Mini Data Center	Central Office	In-country	Large global in country	Large global hyperscale
	Internal enterprise	Internal Government	Network operator	Service provider	Network operator	Colocation/ Metro edge		Cloud
Small <300kW	Scania, LKAB	Customs and Tax agency	Telia, Stokab & Boliden					
Medium 0,3-1 MW		KTH-PDC, Social welfare		Atea, Bahnhof, CityNetwork	Telia, Tele2, Sunet	atNorth, Glesys, Acon, TietoEvy		
Large 1-10 MW	Ericsson					Stack, NData, Conapto		
Hyper >10MW							Equinix, EcoDC, Digital Realty	Facebook, AWS, Microsoft



# Applications driving demand

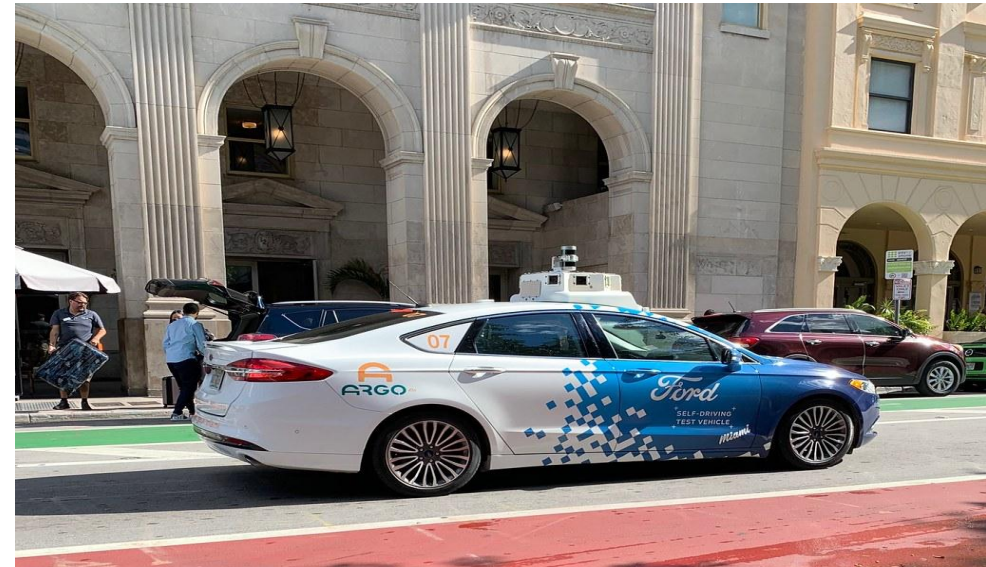

# Applications and their characteristics

Type	Response times	Data amount	Traffic amount	Cache	DC location
Cold storage	seconds	Gigabytes	Mb/s		remote
Off-line big data crunching	seconds	Gigabytes	Gb/s		remote
Chat/IoT type communication	100 <sup>th</sup> milliseconds	kilobytes	kb/s		remote
Web/app rendering	100 <sup>th</sup> milliseconds	Megabytes	Mb/s	Yes	remote
Streaming	10 <sup>th</sup> milliseconds	Gigabytes	Mb/s	Yes	mix
Real-time conferencing	10 <sup>th</sup> milliseconds	Megabytes	Mb/s	Yes	mix
Real-time analytics	milliseconds	Megabytes	Gb/s		proximity
Transaction based/Control loops	milliseconds	kilobytes	kb/s		proximity

# Data center traffic by application 2021

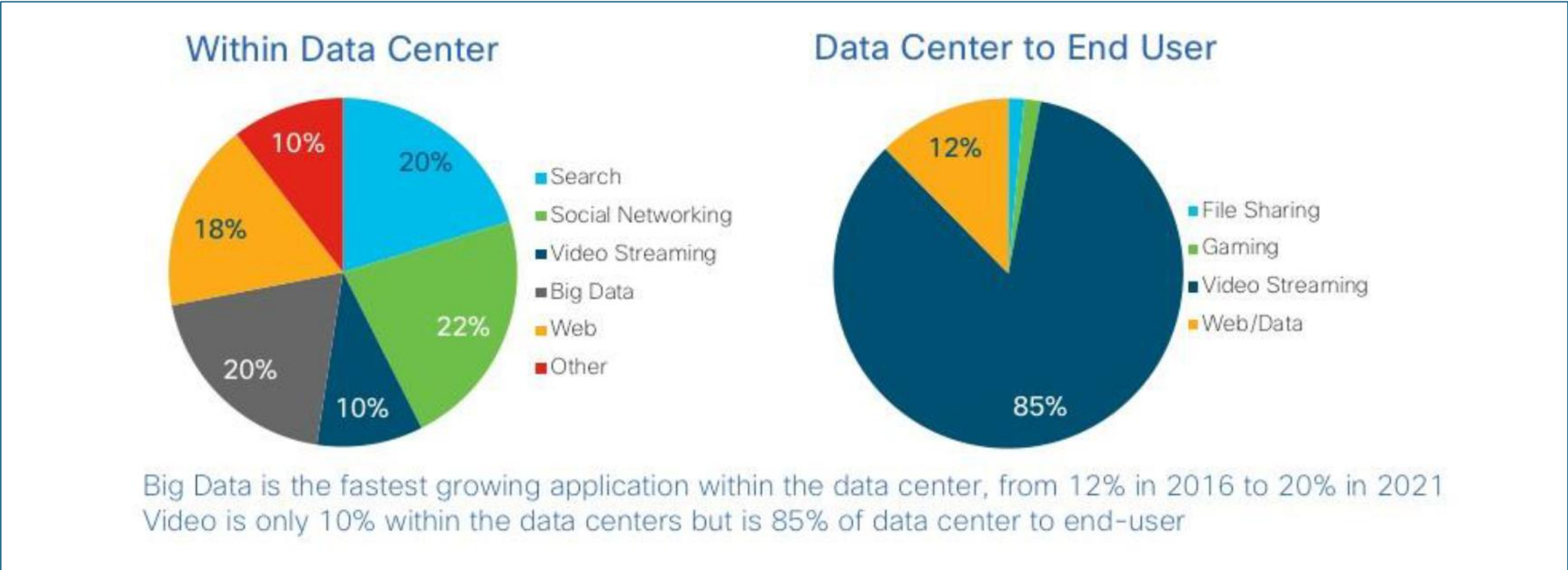

Source: Data center traffic by application (Cisco 2021).



# Data center demand by application 2025

Global data center demand by workload, 2025–30, gigawatts

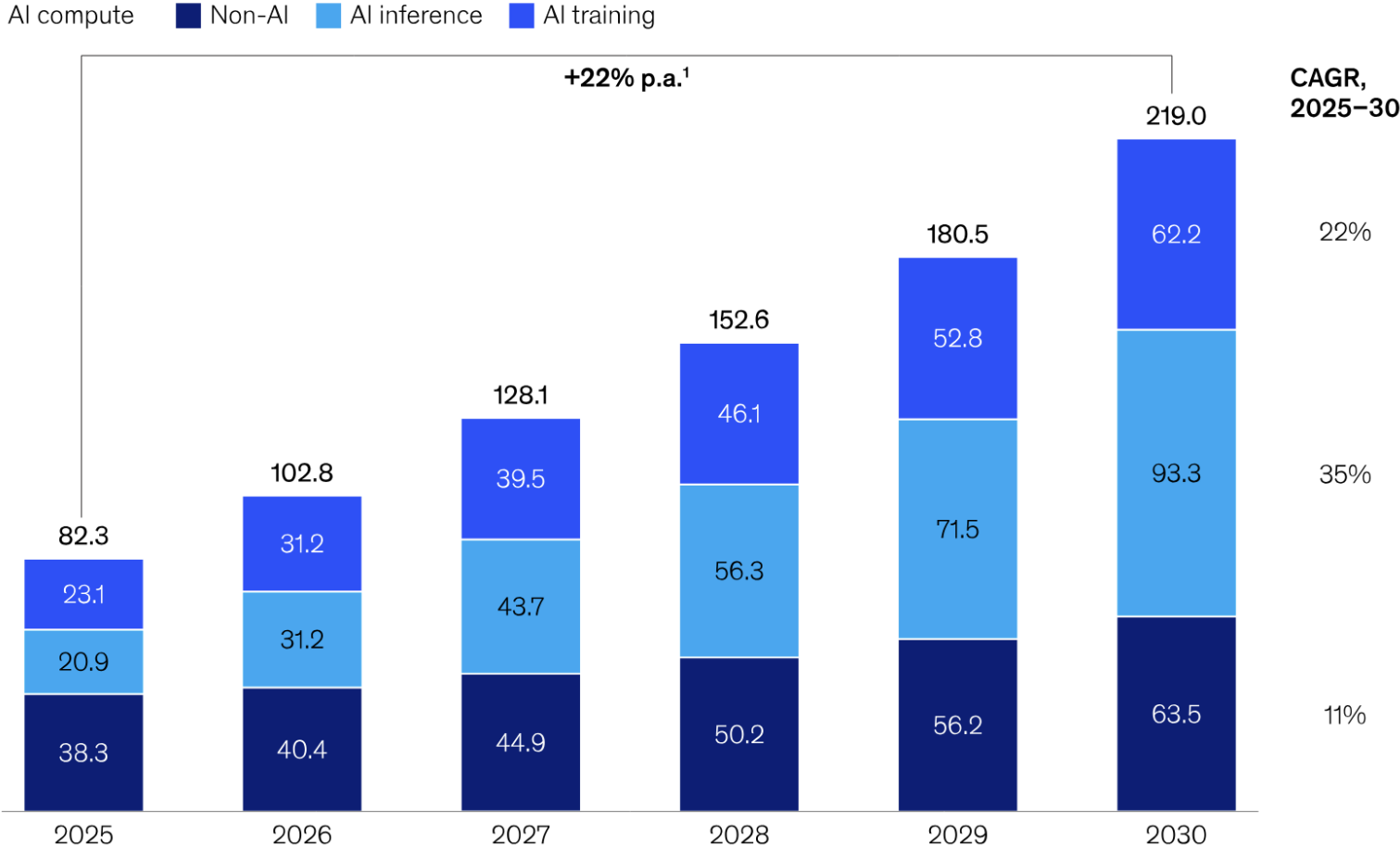

Source: McKinsey 2025



# Data centers vs connectivity investment sizes

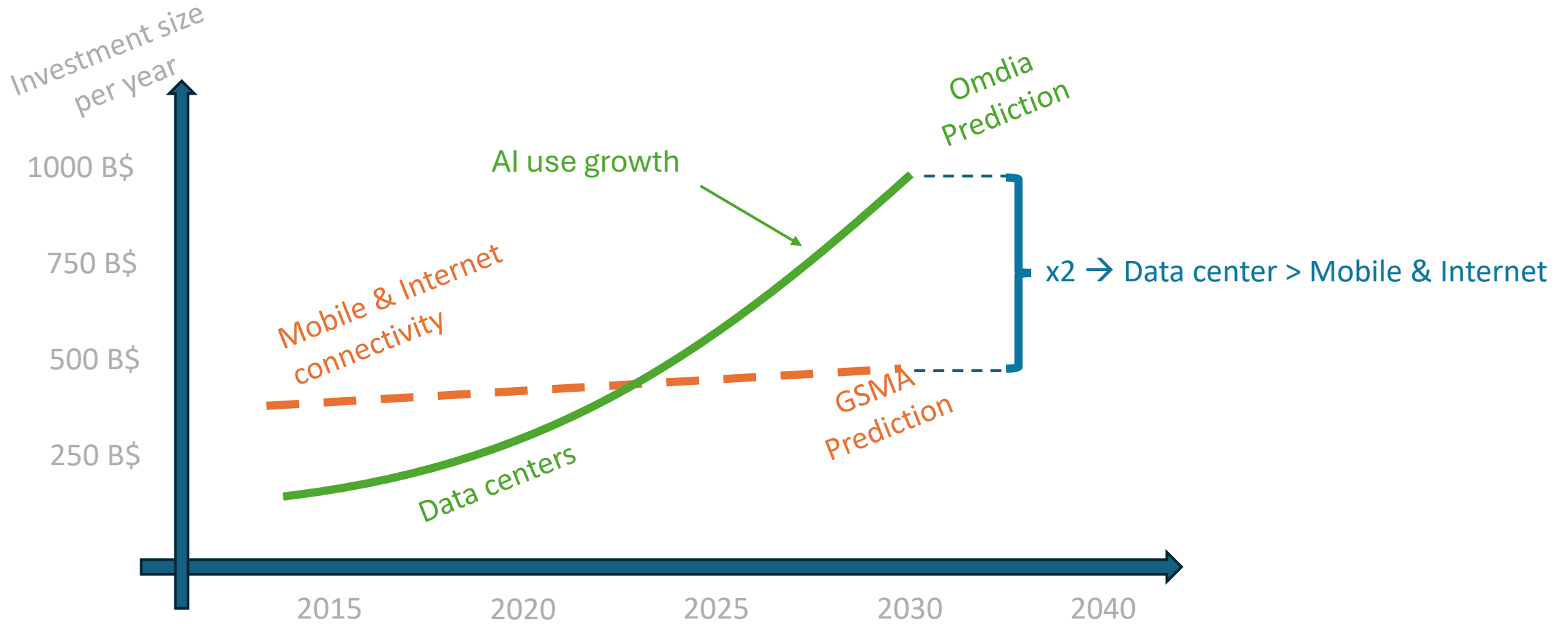

# Data centers vs office construction investment sizes

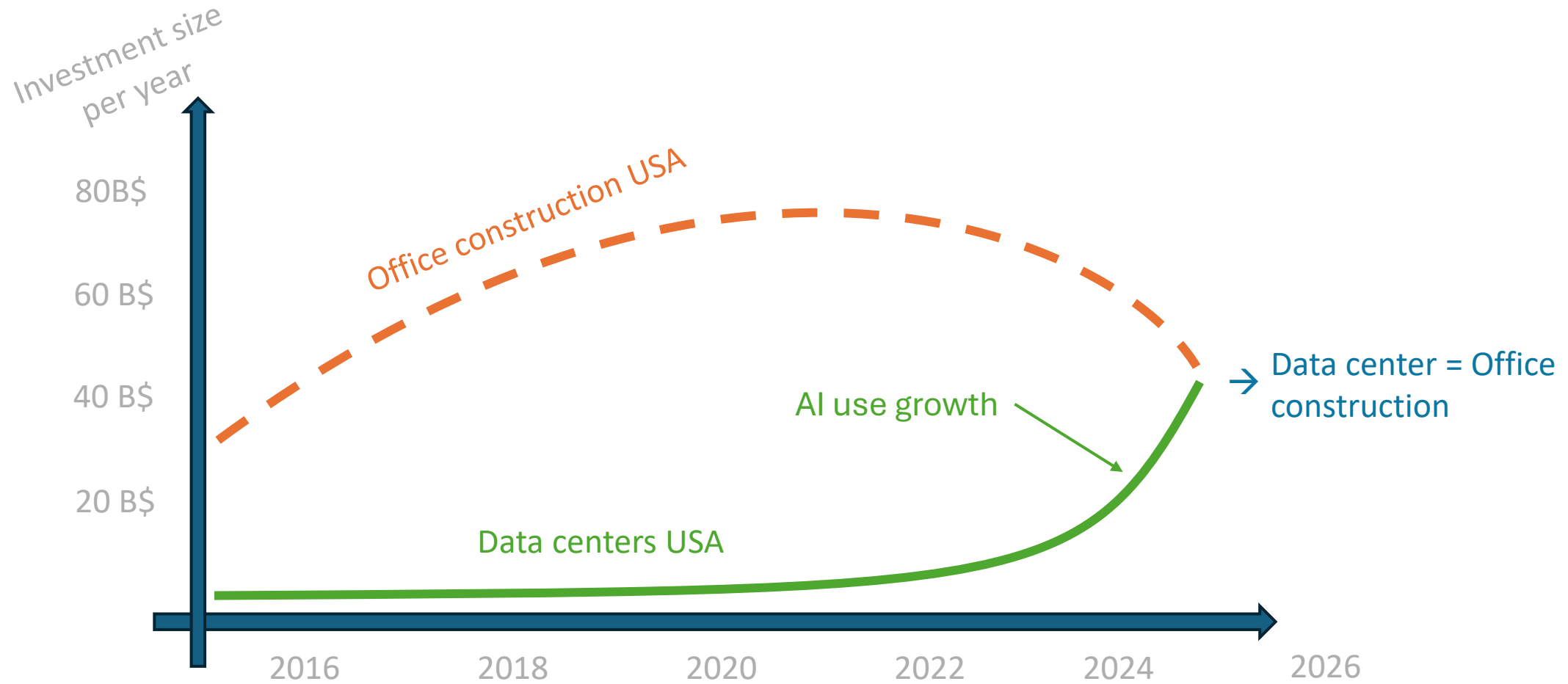

# Global electricity demand in data centers

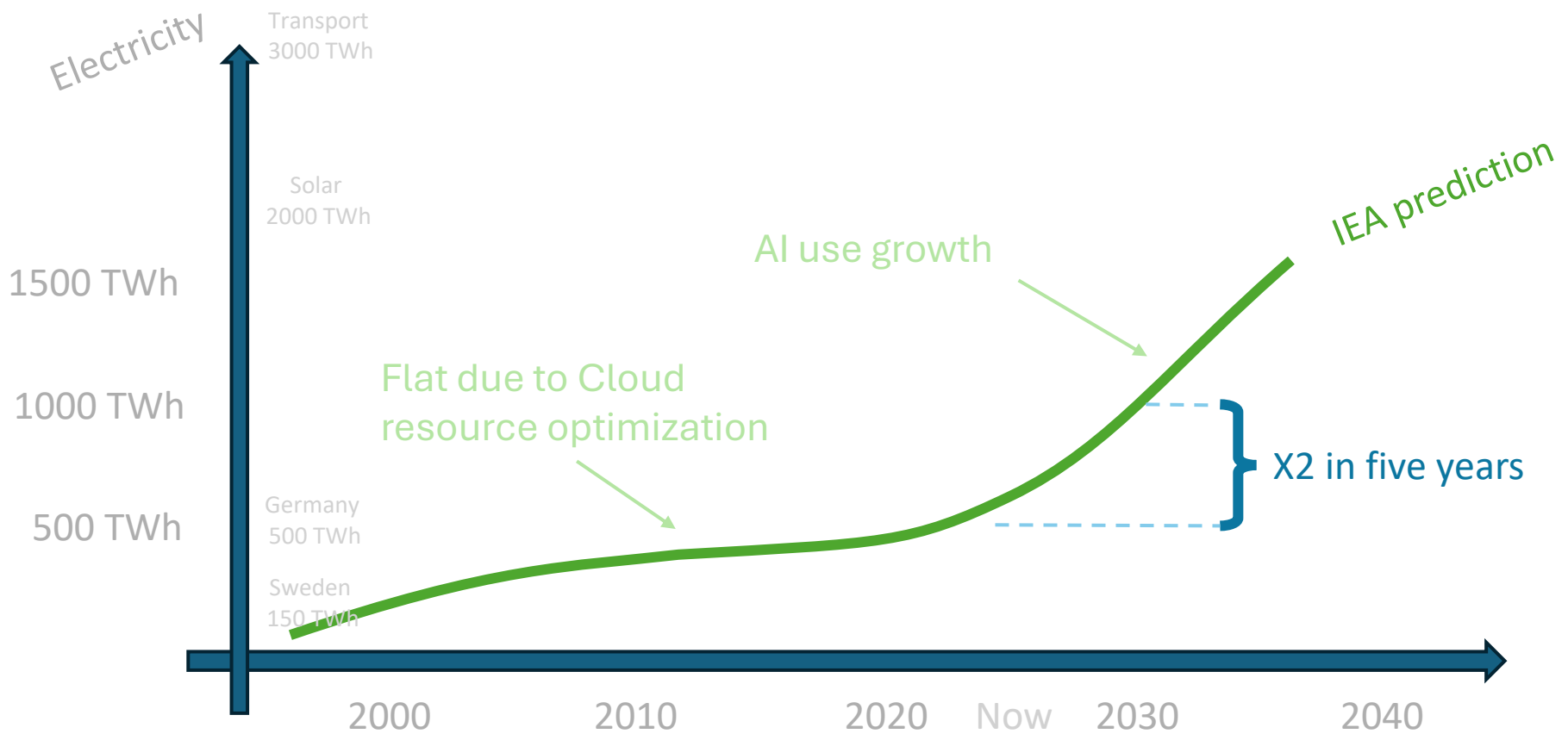

Source: Electricity 2024 Global trends- Analysis and forecast to 2026, IEA 2024



# Swedish electricity demand for data centers

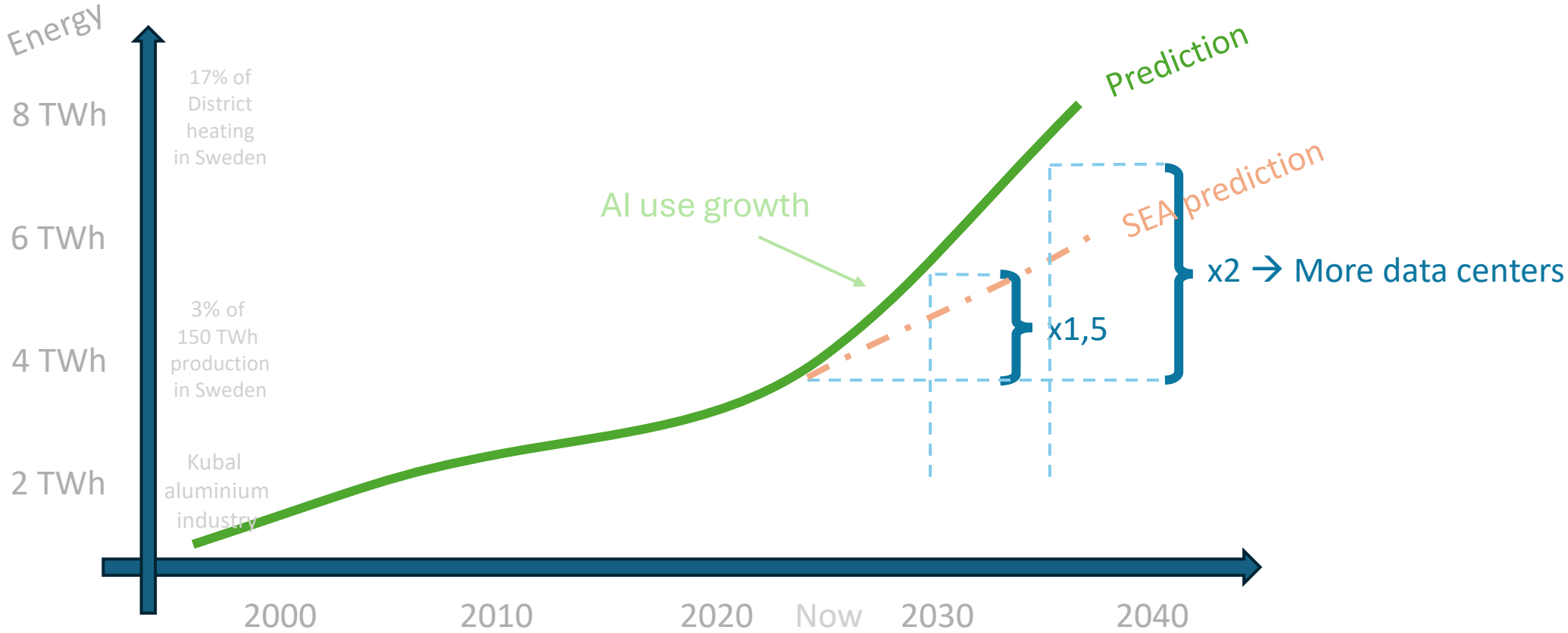

Source: Energianvändning i digitala system, datacenter och kryptovaluta, Energimyndigheten, 2023, RISE 2025



# Data centers in energy terms

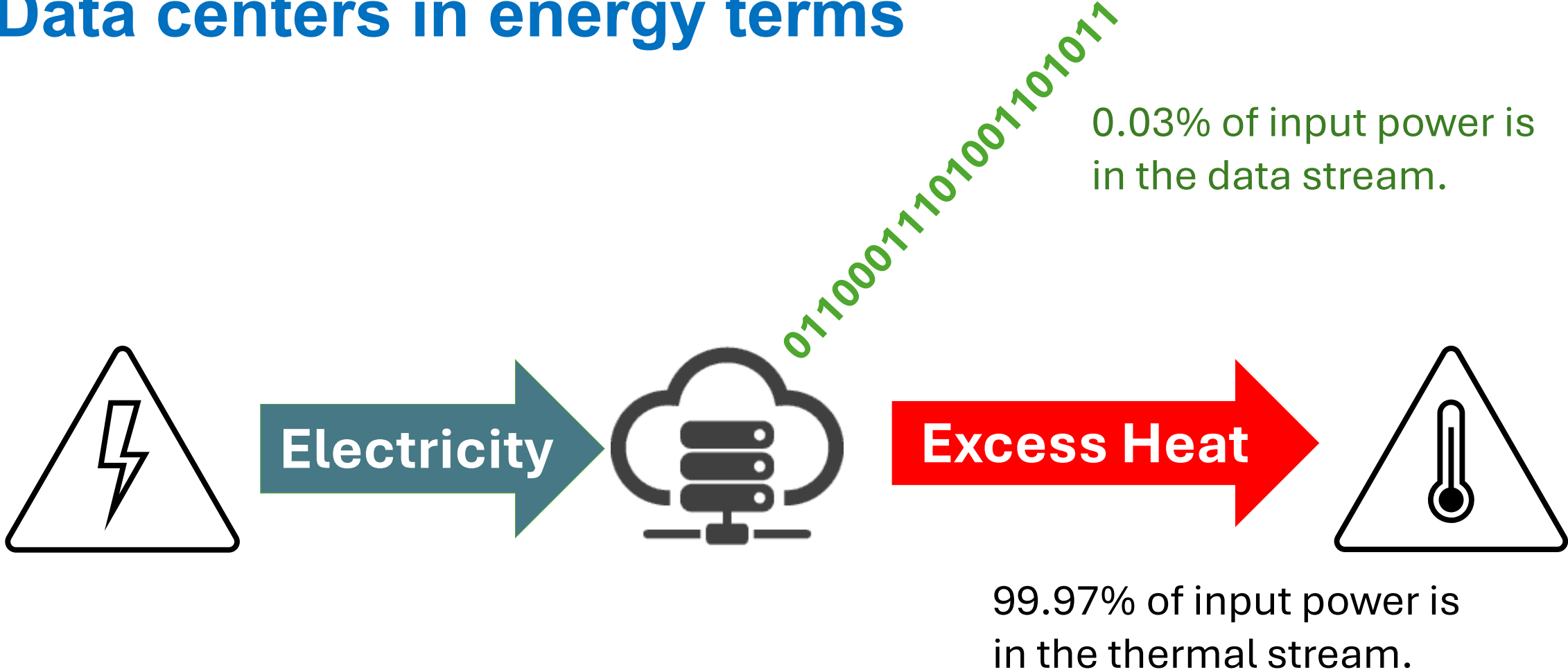

Based on: Rolf Landauer, "Irreversibility and Heat Generation in the Computing Process," *IBM J Res. Dev.* 5, 183 (1961).

# Where do the energy go? 99,97% becomes heat (illustration)

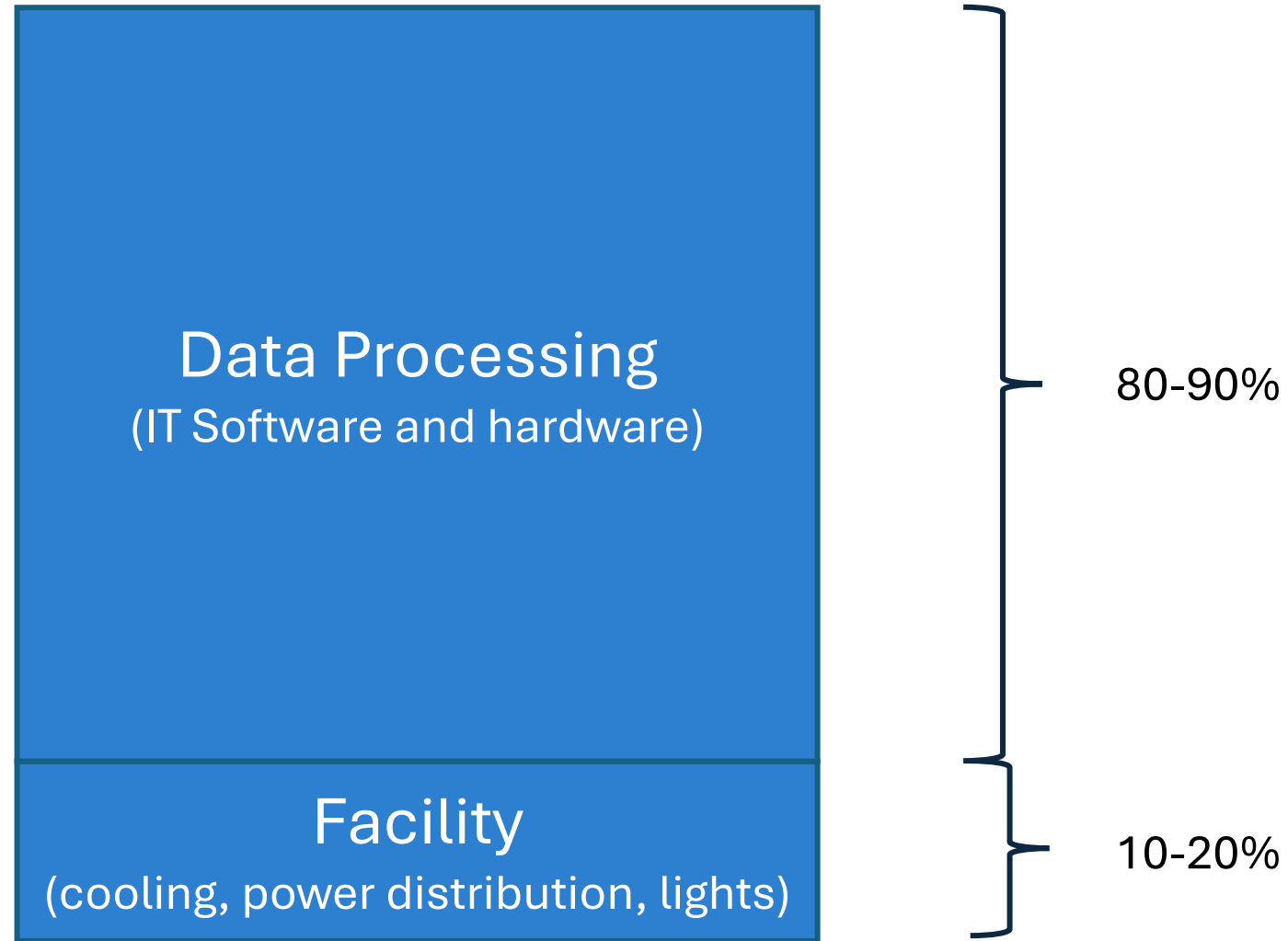

# Size of AI models and training data used

Token or  
Parameter Size

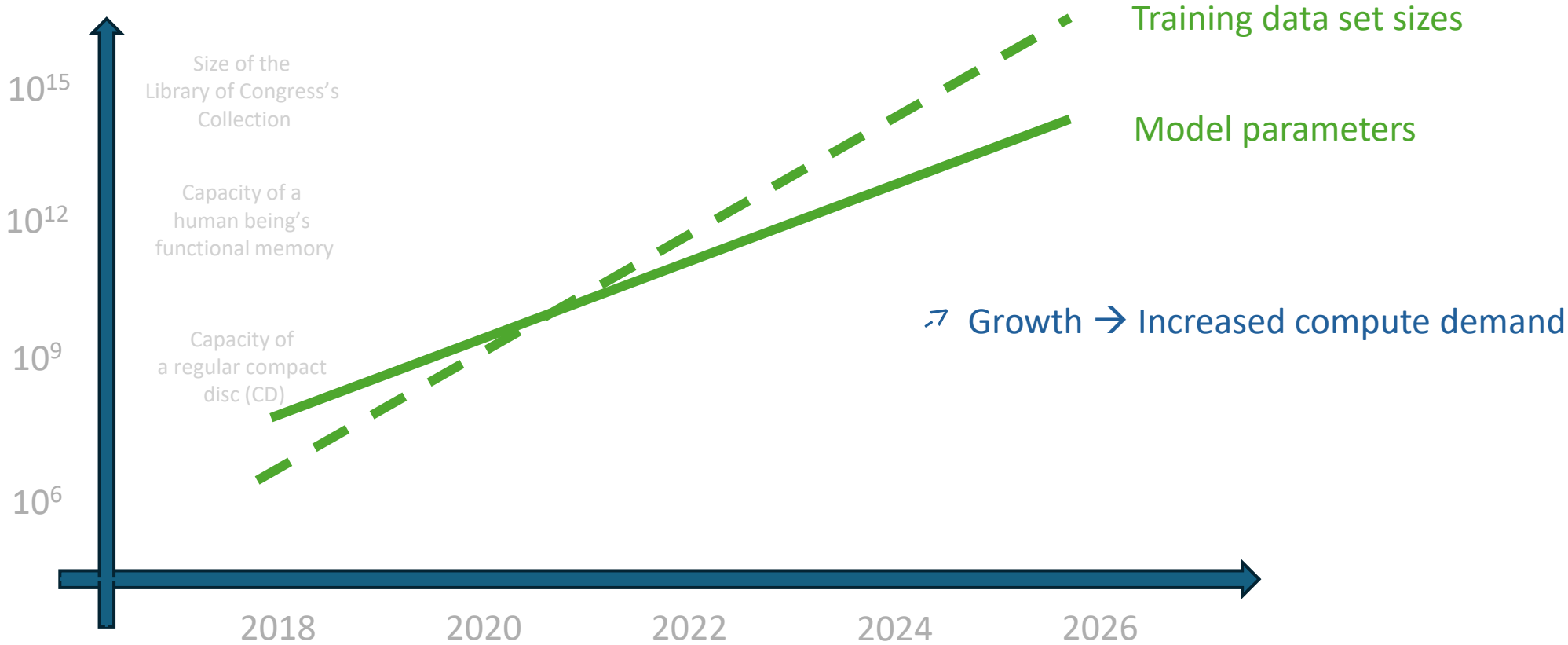

Source: Trends in Training Dataset Sizes, Epoch AI, Sep 20, 2022



# AI compute demand & hardware capability

FLOP = Floating Point Operations

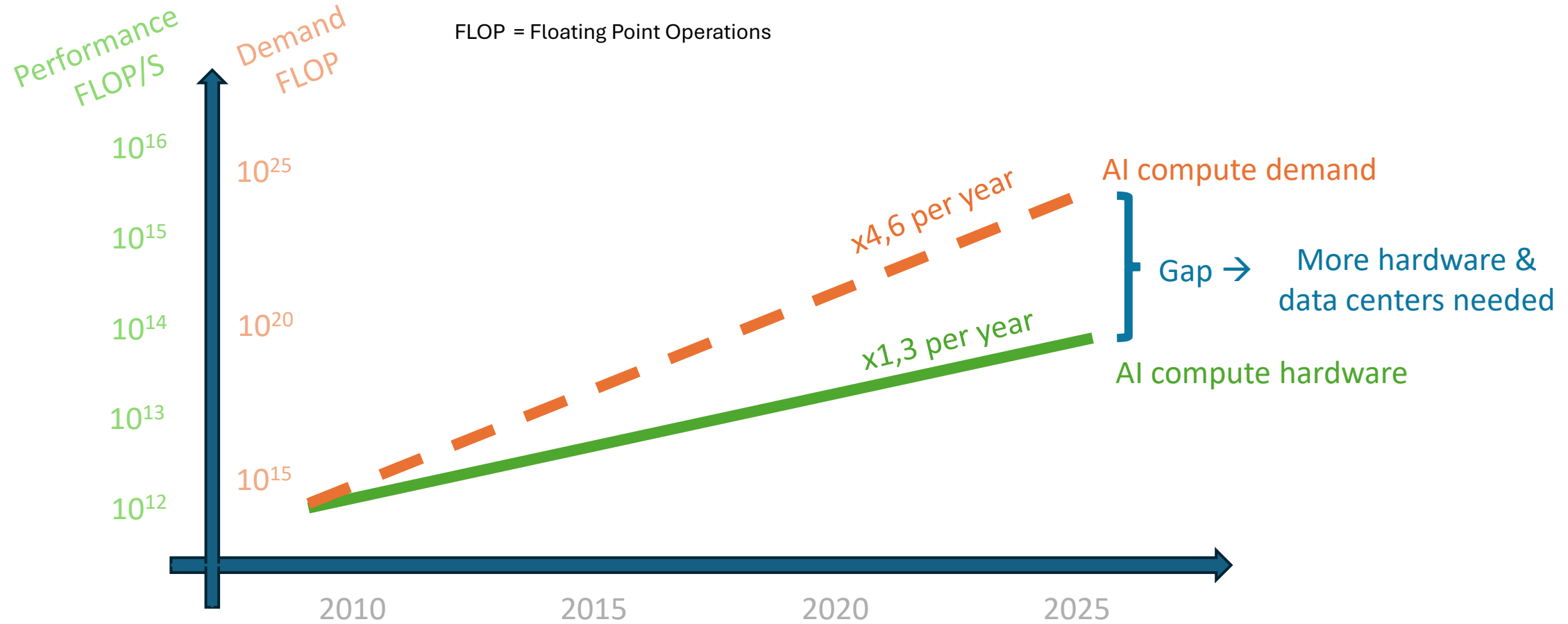

# Development of power in Nvidia GPUs

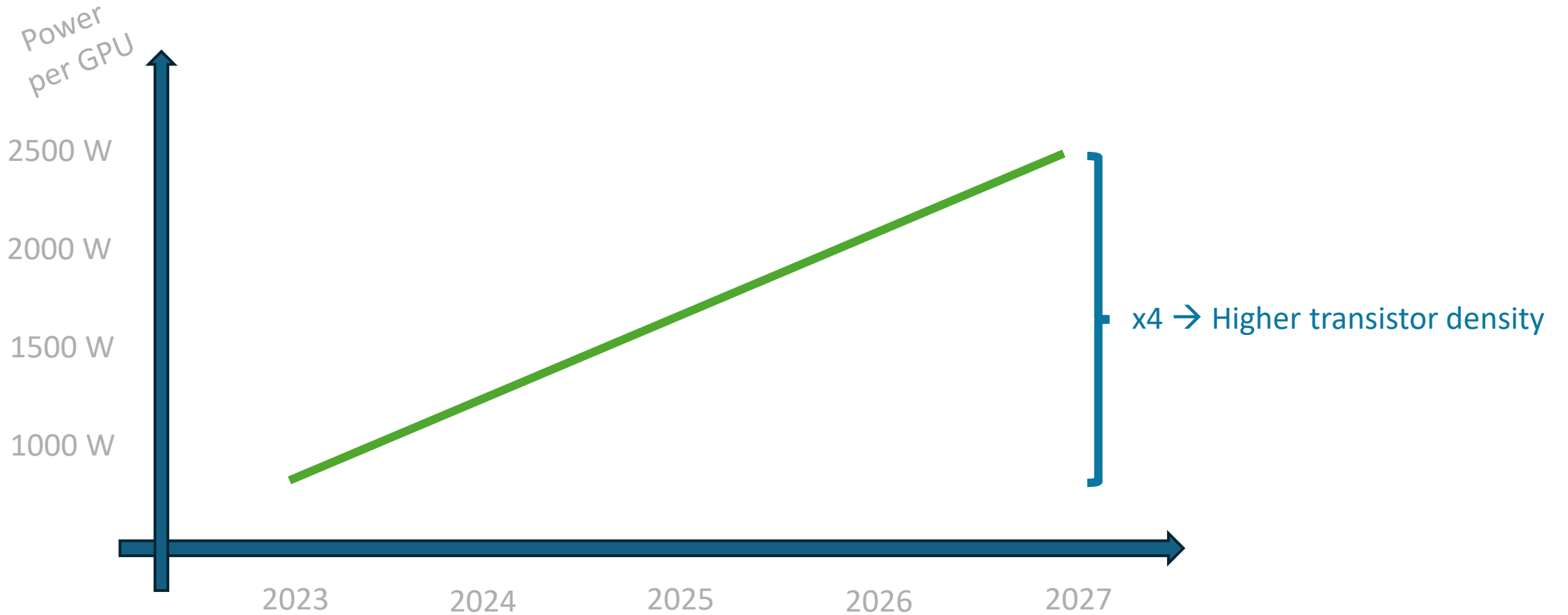

# Development of power in Nvidia GPUs

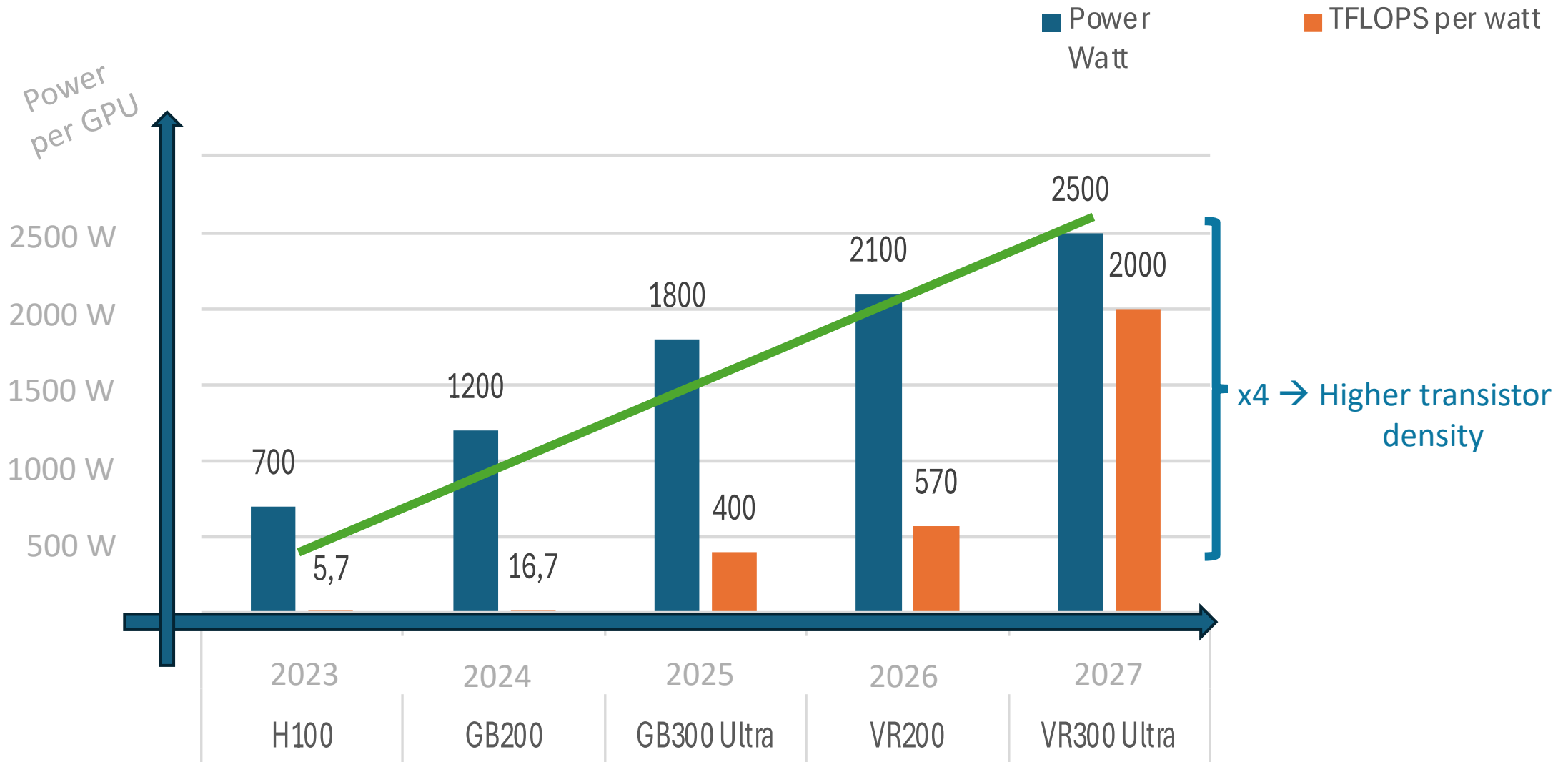

# Development of number of Nvidia GPUs in one rack

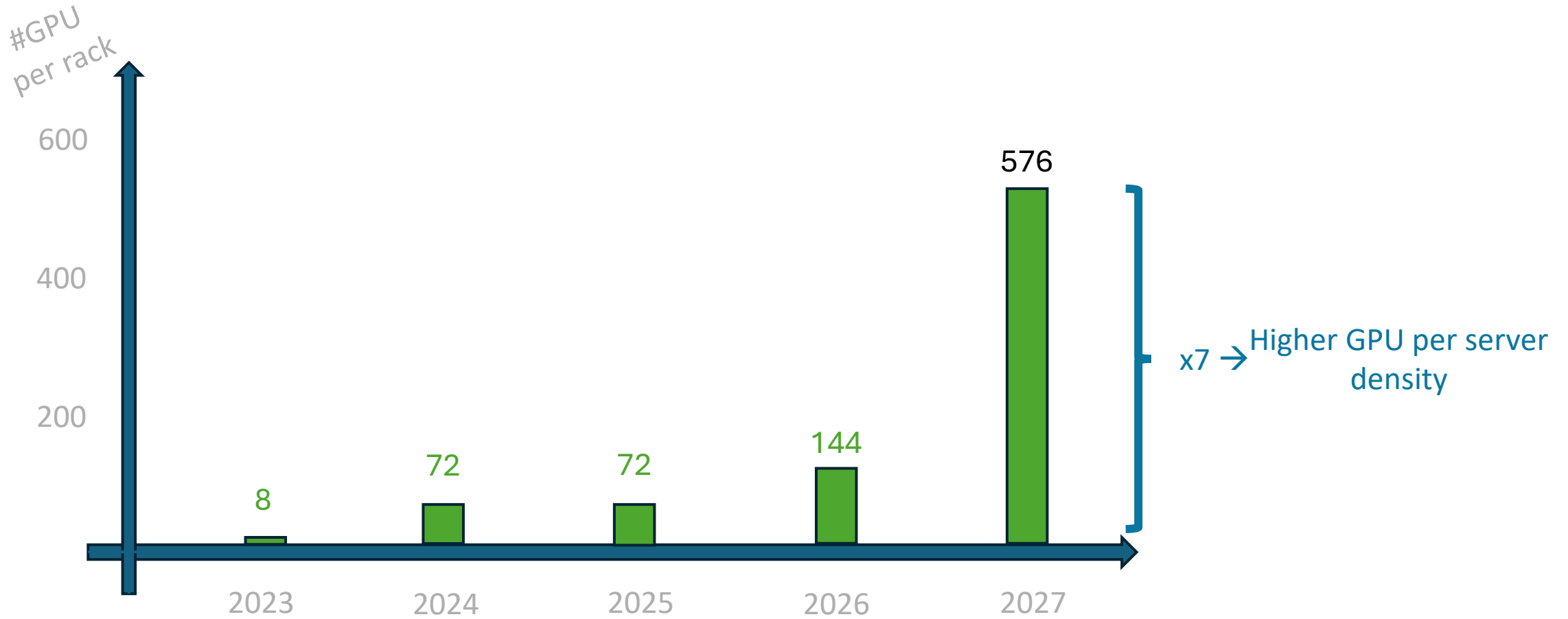

# Comic strip about energy & AI data centers



# Conclusions

- Data centers are a necessity in the society today and is an engine for innovation and growth.
- The growth of data centers outpace other digital infrastructures due to increased demand of AI applications.
- Demanding AI applications require more energy and most of the energy become excess heat. Sweden is a perfect place.
- New micro processors and algorithms improve performance and energy efficiency but can not keep up the demand.
- Sweden has a strong data center industry that needs some love

# Nationellt behov av energi till datahallar

Rebecca Roupe  
Kundansvarig Region Mitt  
Svenska Kraftnät

SVENSKA KRAFTNÄT

# Effektbehov Datacenter

260427

# Övergripande ansökningsläget Svenska kraftnät



# Effekt tilldelad i förhandsbesked år 2018–2026

År	Inmatning, MW	Uttag, MW
2018	3 395	761
2019	9 760	1 407
2020	488	1 050
2021	1 219	241
2022	1 100	3 532
2023	3 045	715
2024	1 142	1 923
2025	1 170	3 695
2026	172	211
<b>Total</b>	<b>21 491</b>	<b>13 535</b>

# Ansökningsärenden i kö per 31 mars 2026

exkl vindkraft hav

**Totalt ansökt effekt i kö:**

**Inmatning: 22 487 MW**

**Uttag: 34 180 MW**

*Topplast Sverige 2025: 22 500 MW*

**Totalt antal ärenden i kö: 105**

**Ansökt effekt per län, Dalarna**

**Inmatning: 700 MW**

**Uttag: 1 100 MW**

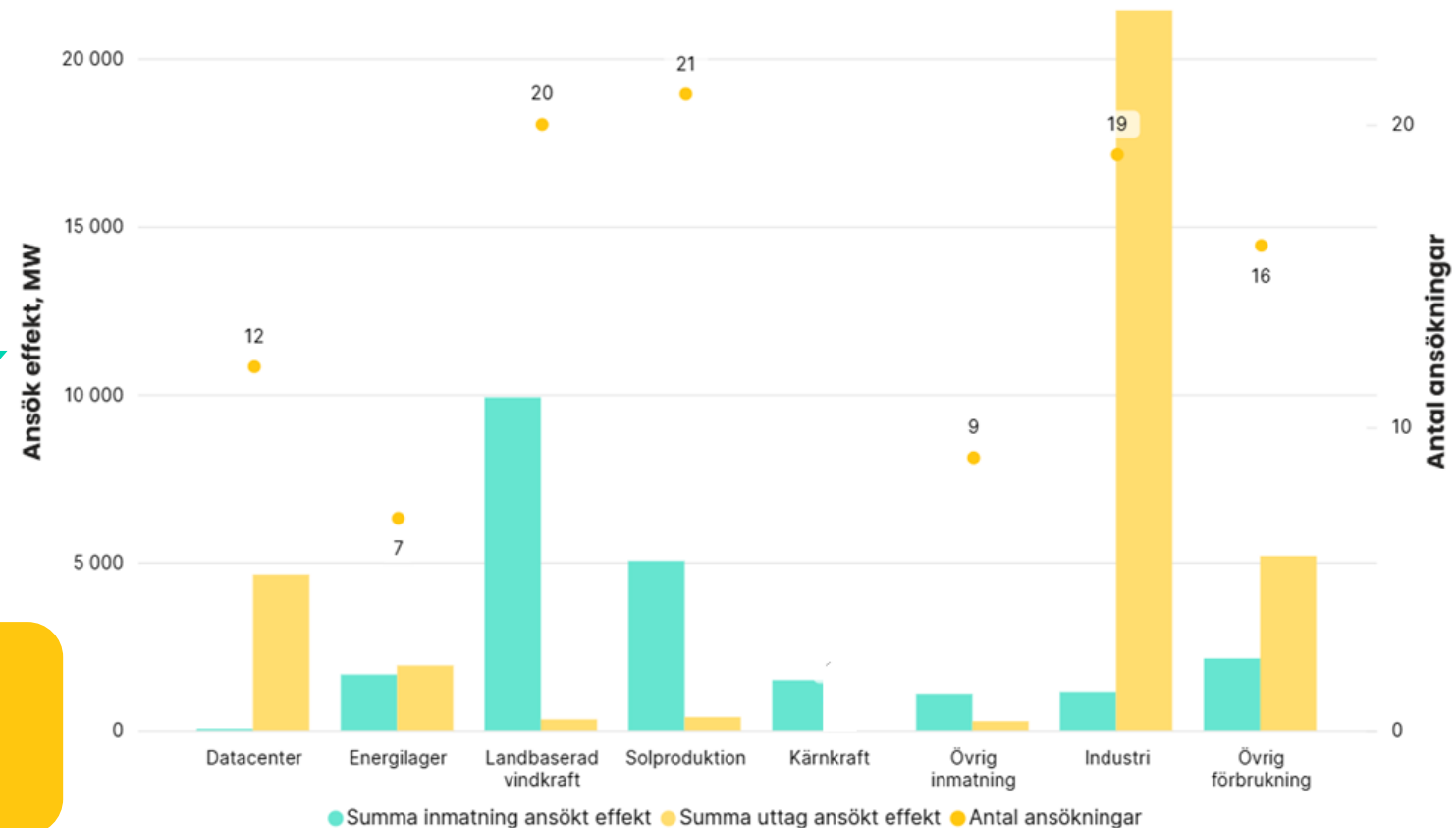

# Ansökningsärenden i kö per 31 mars 2026

exkl vindkraft hav

## Undersökning ej startad:

26 120 MW

64 st

## Undersökning pågår:

30 547 MW

41 st

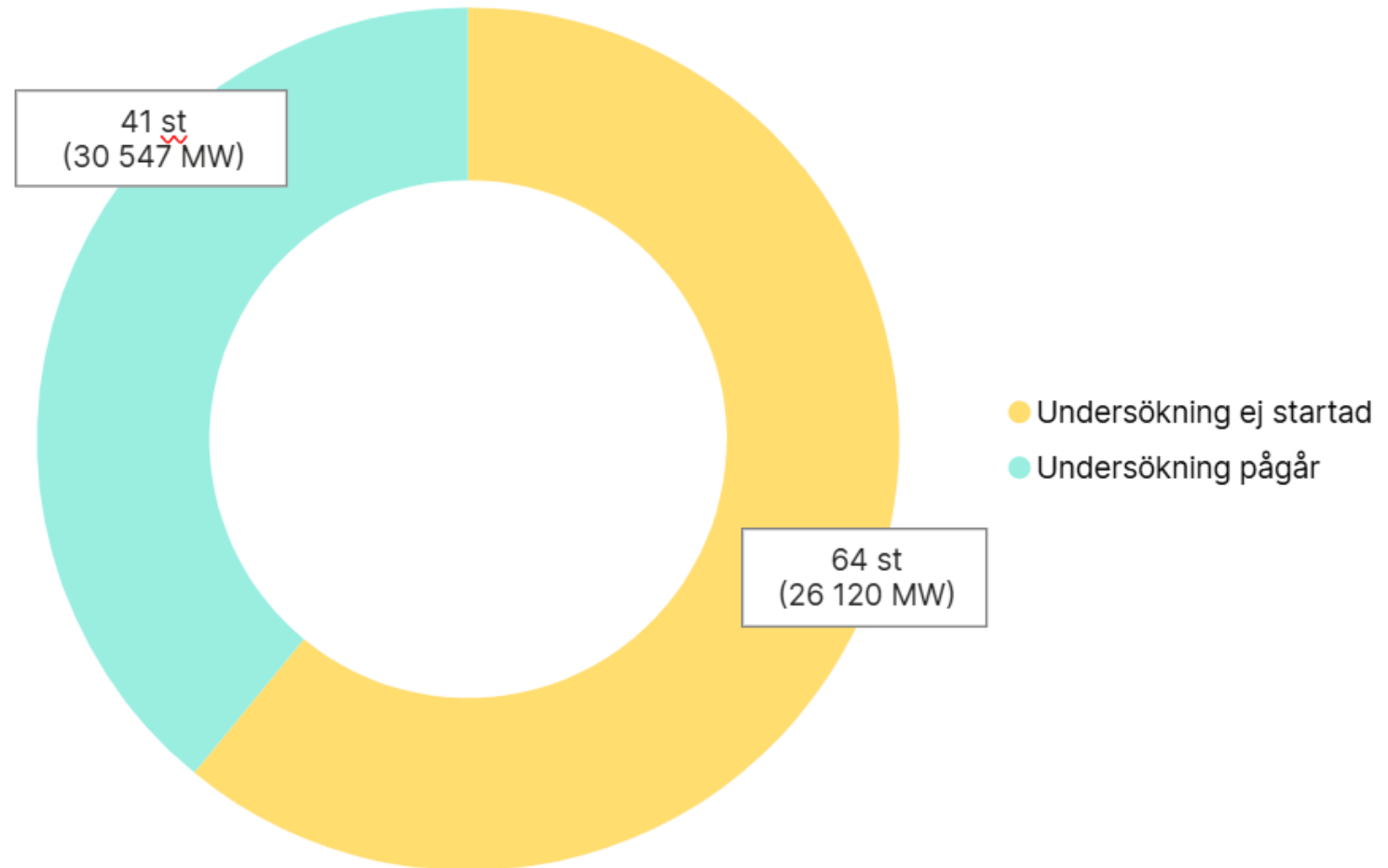

# Driftagningsår - ansökt, reserverat, tilldelat per 31 mars 2026

## Elproduktion

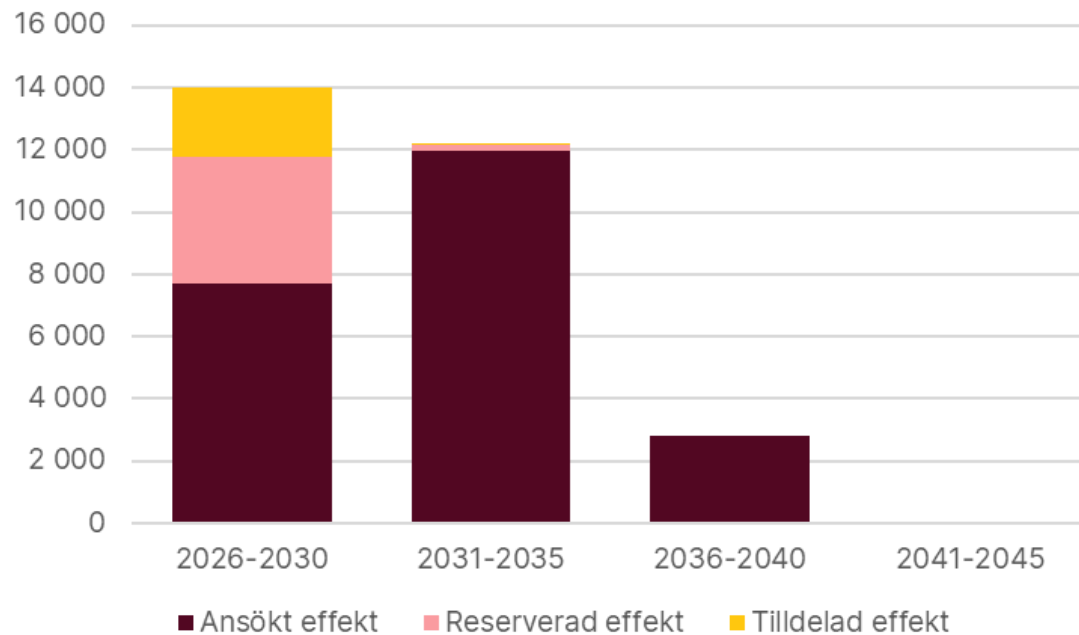

## Elanvändning

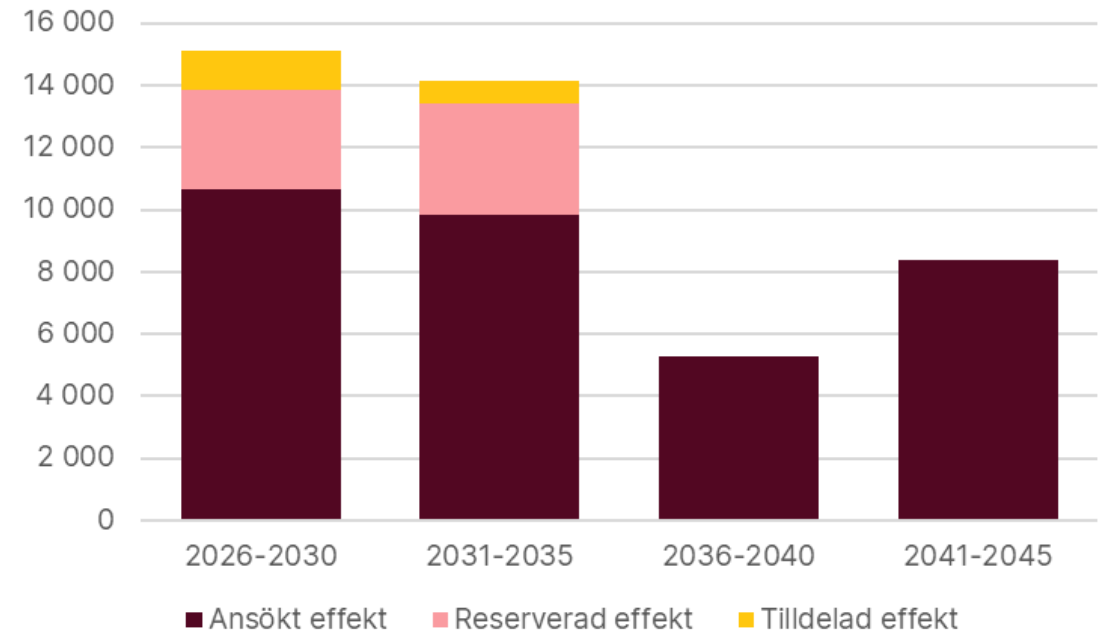

*Ansökt effekt* – ansökningar i kö som inte fått förhandsbesked

*Reserverad effekt* – effekt som reserverats i förhandsbesked, men där inget signerat anslutningsavtal finns ännu

*Tilldelad effekt* – effekt i anslutningsavtal som är tilldelad, med idrifttagning sker efter 2026

# Effektbehov datacenter



# Efterfrågade uttagskapacitet för stora datacenter nationellt är just nu 7 620 MW



Avtalad effekt i anslutningsavtal under år 2024 och 2025	Reserverat i förhandsbesked	Undersökning pågår	I kö
1 680 MW	600 MW	1 480 MW	3 860 MW

# Efterfrågad kapacitet för stora datacenter i mellersta Sverige är just nu 6 410 MW

Efterfrågade kapacitet för datacenter, summerat för norra och södra Sverige under samma period är 1 210 MW

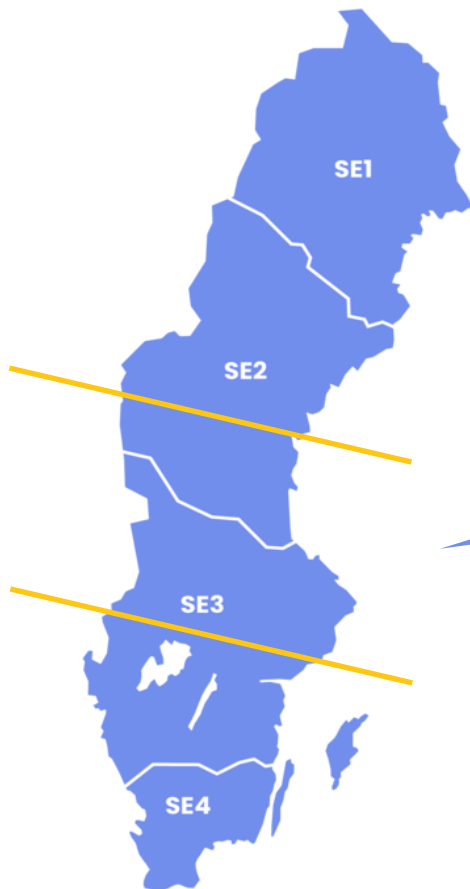

Avtalat	Reserverat	Undersökning pågår	I kö
1 380 MW	200 MW	1 300 MW	3 530 MW

# Summering

- Svenska kraftnät ser **fortsatt högt tryck** i ansökningar generellt samt för datacenter specifikt
- Kraftig ökning av effektuttag på kort tid kommer ha påverkan på elsystemet och på elpriset givet allt annat lika
- Svenska kraftnät har ett **pågående uppdrag från regeringen** att se över anslutningsprocessen för anslutning till elsystemet och tillträde till elmarknaden för **ett starkare och mer konkurrenskraftigt Sverige**
  - Införande av anvisningssystem för olika kundkategorier
  - Matchning av lastprofiler mellan anslutande aktörer
  - Finansiella kontrakt (PPA:er) som bevis på matchning och/eller som krav i anvisningssystem



# Datahallar i Dalarnas energisystem

Kerstin Lisspers  
Länsstyrelsen Dalarna

# Scenarier för hur Dalarnas el kommer att produceras och användas 2030 & 2045 jämfört med 2024.

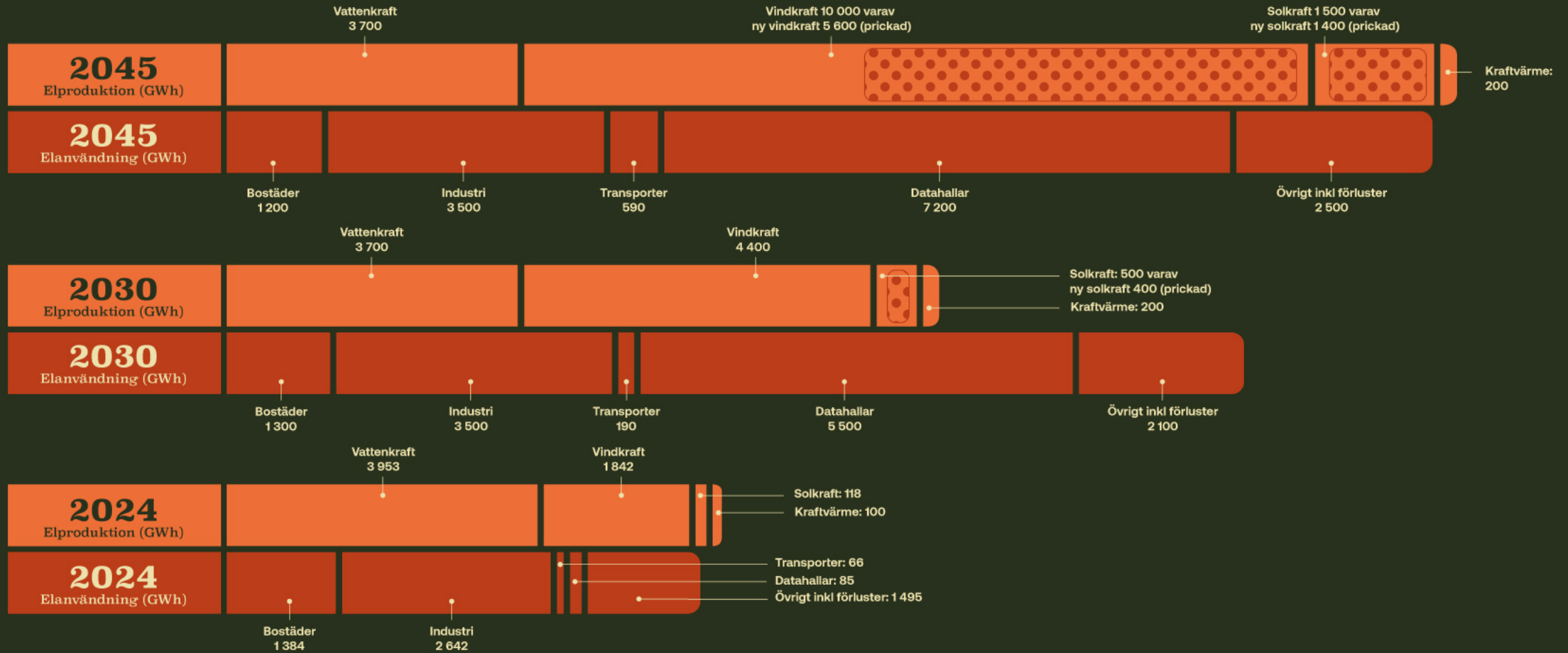

## Effektbehov topplaststimme

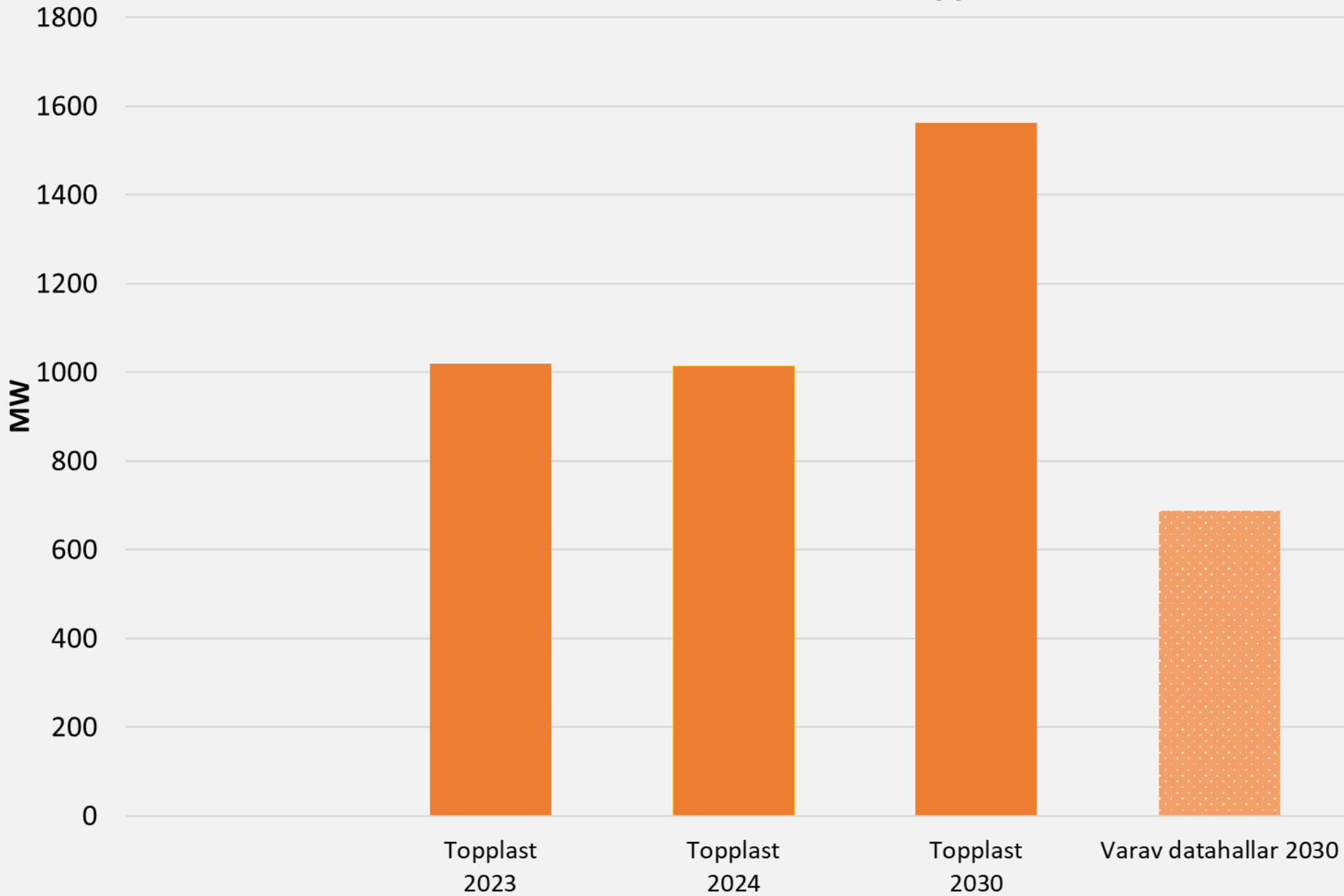

# Effektprofil

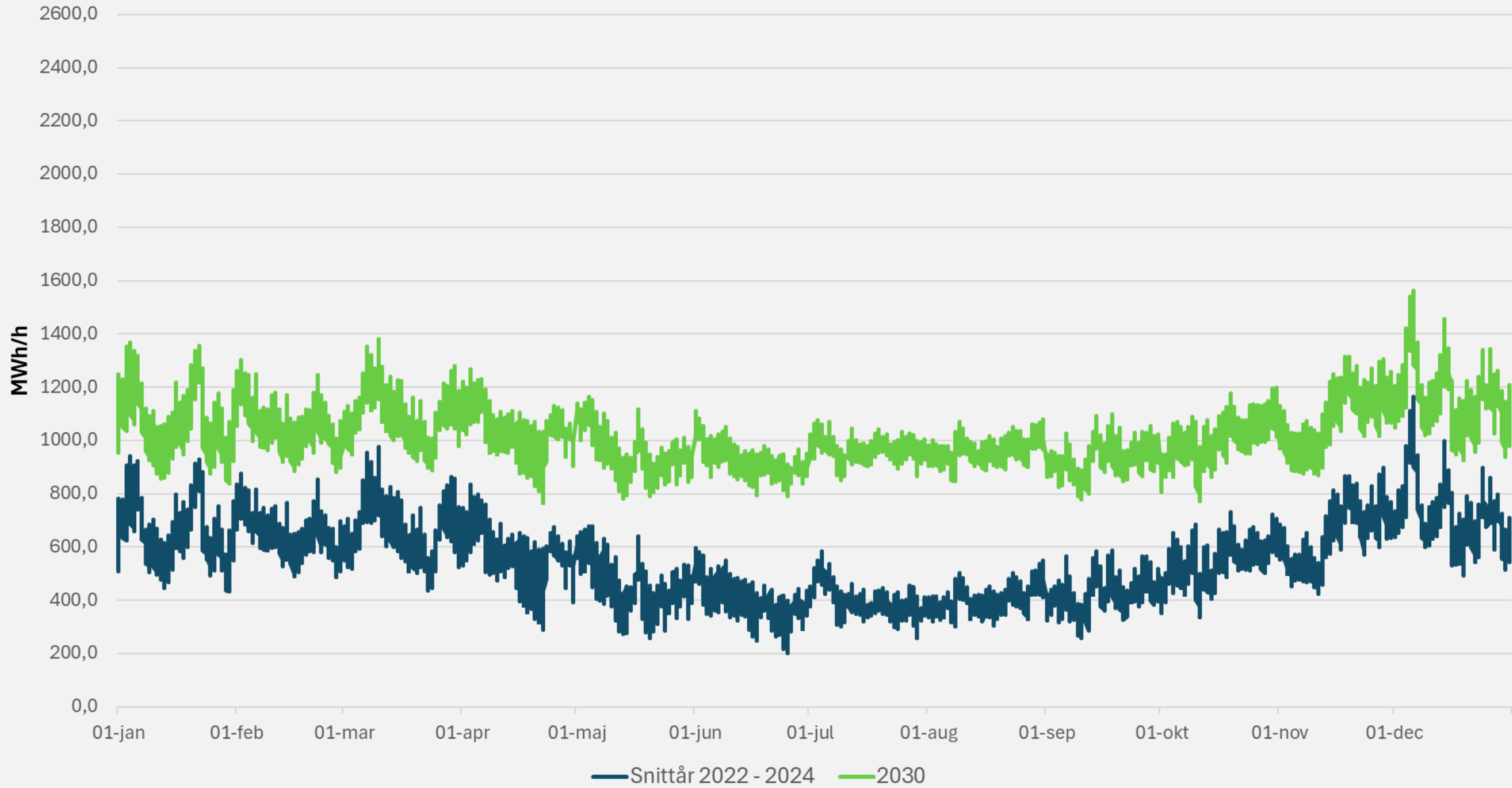

# Tack!



# Etablering av hållbara datahallar

Isabelle Kemlin

Vice-chair Sweden Data Center Industry.  
Vice-chair European Data Centre Association.  
Business and Innovation Executive RISE Data center systems.



**RI.  
SE**

# **Vad krävs för att etablera hållbara datahallar?**

**RISE – Research Institutes of Sweden, SweDCI, EUDCA**

**Isabelle Kemlin**

# Agenda

- Vad är ett hållbart datacenter?
- Teknik och energival
- Energieffektivitet
- HUR kan vi använda värmen som genereras?
- Datacenter som en del av energisystemet
- Energieffektivitetsdirektivet
- VAR ska vi lokalisera datacenter, sett ur ett hållbarhetsperspektiv?

# DINA DATAFLÖDEN I VARDAGEN

MINST 40 DATACENTER PER DAG



**Du och jag -  
interagerar med  
ett datacenter  
20-40 gånger  
per dag**

# Hållbara datacenter: Hur skapar vi digital tillväxt på ett ansvarsfullt sätt?

Viktigt att se på hållbarhet ur ett helhetsperspektiv: En verkligt hållbar anläggning uppnår prestanda, motståndskraft och ansvar - och levererar sömlös drift samtidigt som den minimerar koldioxidavtryck, resursförbrukning och ekologisk påverkan.

## Hörnstenar för ett hållbart datacenter



### Energieffektivitet

Optimerad kylning, serveranvändning och energihantering.



### Drivs av förnybar energi

Övergång till 100 % ren energi genom sol-, vind- och vattenkraftkällor med batterilagring för nätoberoende.



### Cirkulär design

Återanvänd, reparera och återvinn IT- och byggmaterial. Utrustningsrenovering, komponentåtervinning och ansvarsfull hantering av e-avfall förlänger livscykeln och minskar



### Vattenklok verksamhet

Slutna kylsystem, insamling av regnvatten och återvinning av gråvatten minimerar uttag av färskvatten och utsläpp av avloppsvatten.



### Datadriven optimering

Realtidsövervakning, optimering och transparent rapportering som möjliggör kontinuerliga effektivitetsförbättringar och ansvarstagande.

A photograph of a server room with blue lighting and bokeh effects. The text is overlaid on the left side of the image.

**Är datacenter  
energieffektiva? Vad görs  
för att effektivisera dem  
ytterligare?**

# Elanvändning i jämförelse

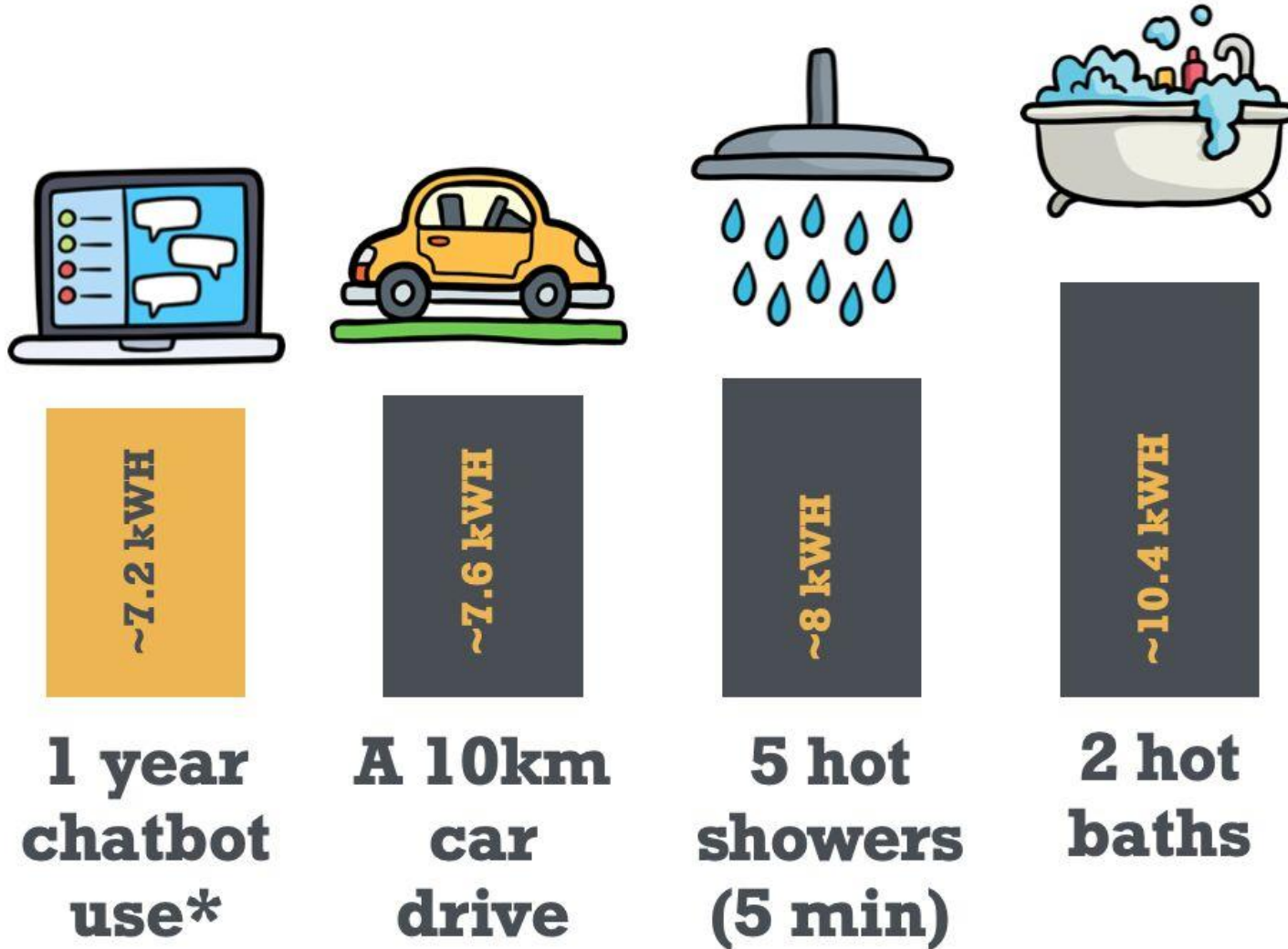

**Kyla servrarna är en  
av de största  
tekniska  
utmaningarna!**

**Idag varmt som en  
raket....**

**I morgon som ett  
kärnkraftverk.**



# För att kyla behöver vi vätska framöver!

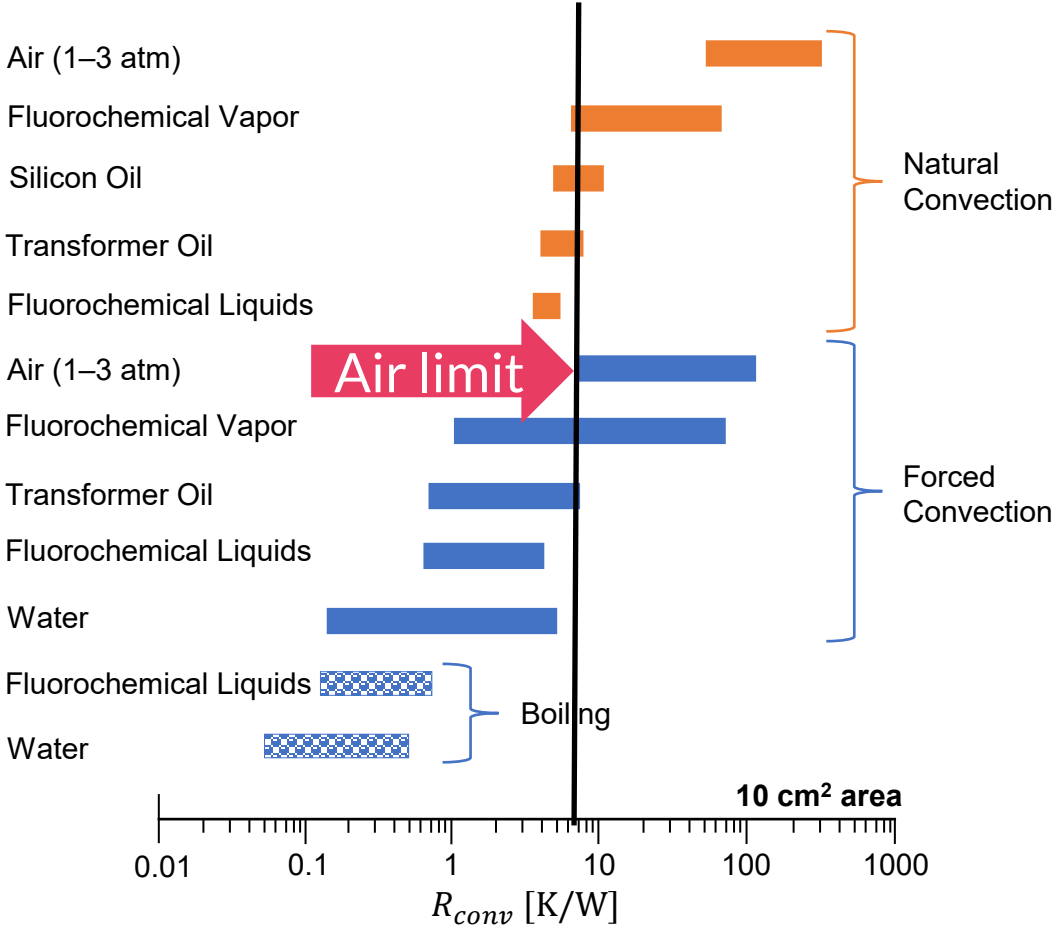

Ahmed El-Neema based on Tummala, R.R. 2001.  
 Fundamentals of Microsystems Packaging. McGraw-Hill.



# Introduktion till olika typer av kylning

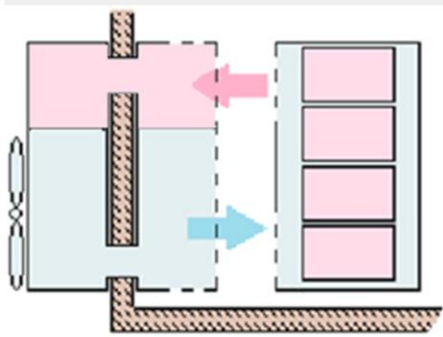

Full Air (some liquid for economizer)

Peripheral liquids

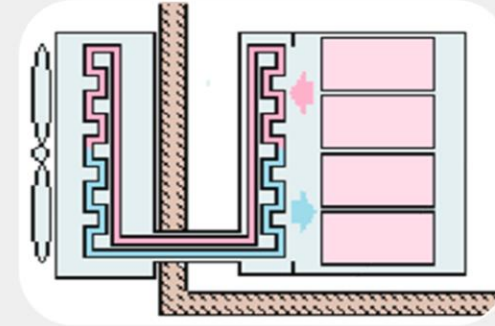
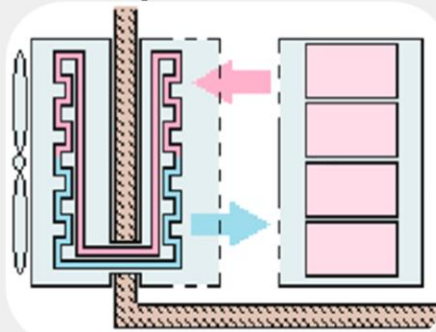

Proximity liquids = Indirect Liquid

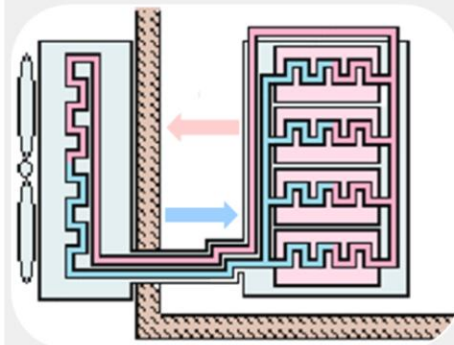

Direct Liquid

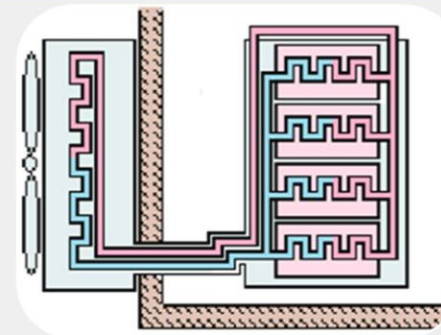

Total Liquid

# Två dominerande vätskekylningsmetoder, med många variationer

Direct-to-chip, “cold plates”

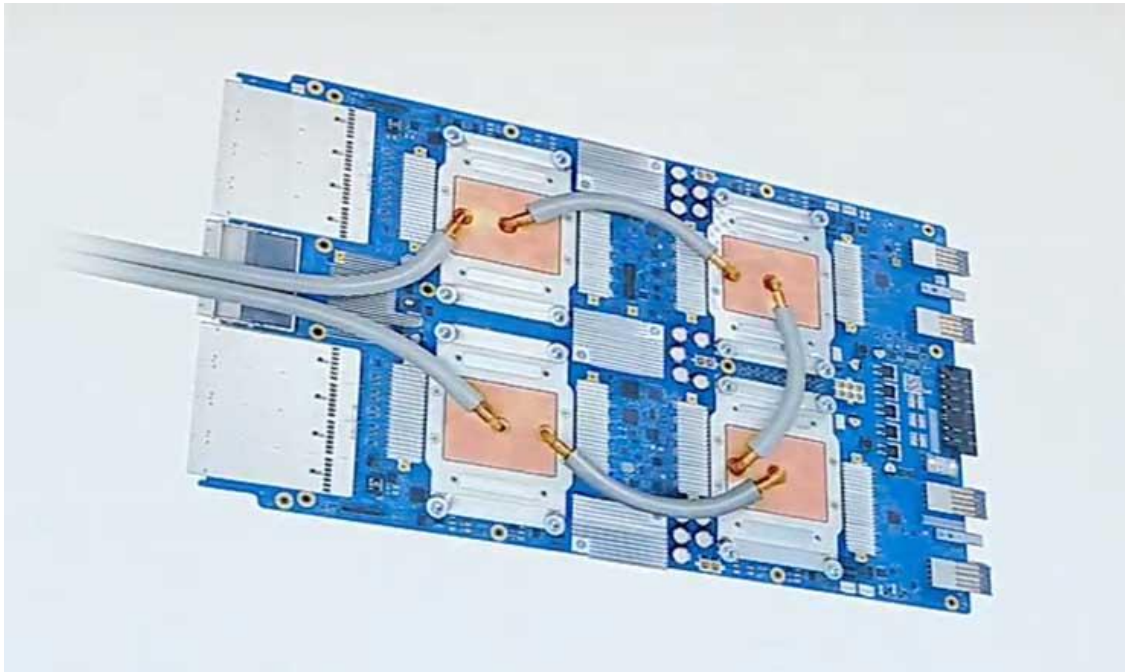

An image of Google's new TPU 3.0, showing the piping to support liquid cooling. (Image: YouTube)

**Note: there are hybrid systems appearing.**

Immersion



Source: image of proof-of-concept in laboratory at the University of Leeds courtesy of Asperitas, 2017.



# Testbäddar på RISE



RI.  
SE

**HUR kan vi ta vara på  
värmnen?**

# Exempel på värmeåtervinning

- Värma hus
- Torka trä
- Värma växthus
- Odla fiskar, humrar
- Odla maskar..



# Datacenter som en del av energisystemet



# Vad kan datacenter *tillföra* elnätet?

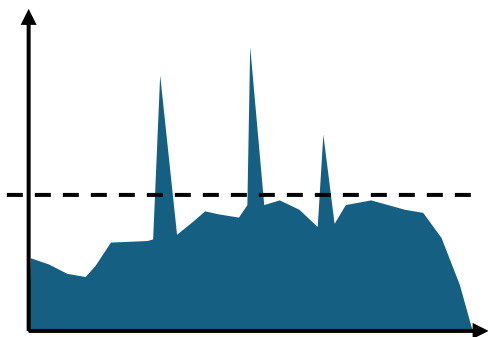

Peak  
shaving

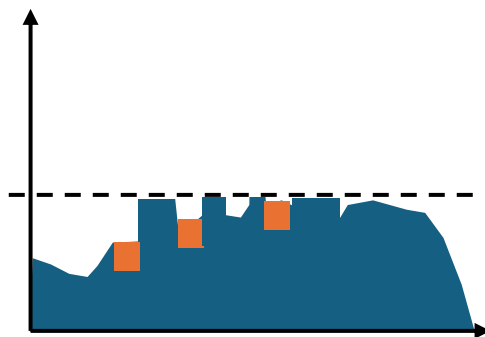

Energi-  
arbitrage



Ancillary  
services

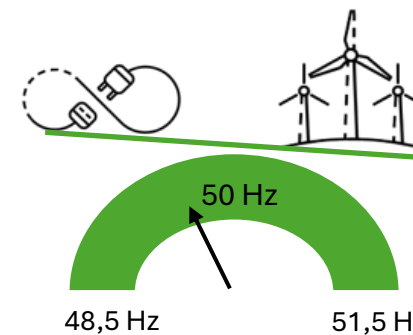
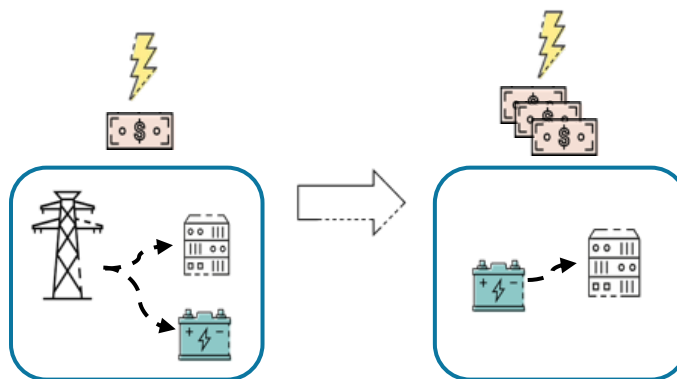
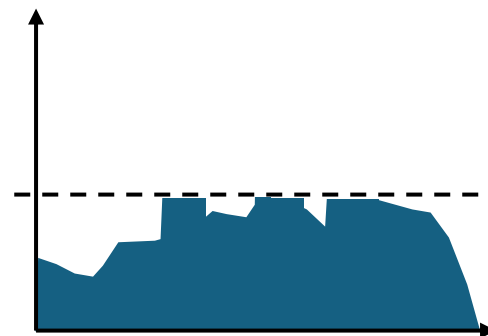

**Egen elproduktion?**



# Översikt av Energy Efficiency Directive och dess mål



## **Vilka omfattas?**

Alla datacenter över 500 kW IT last, måste rapportera ett flertal KPIer.

## **Hållbarhetsmål**

Direktivet stödjer Eus "Green Deal" och syftar till att ha klimatneutrala datacenter 2030.

## **Standardisering och transparens**

Regleringen stödjer standardiserad datainsamling och ger en ökad transparens inom EU:s medlemsstater.

## **Kontinuerlig förbättring**

Direktivet är tänkt att fostra en kultur med målet att ha ständiga förbättringar vad gäller energieffektivitet inom digital infrastruktur.

# Nästa steg i utvecklingen av lagen (EED)



## Hållbarhetsklassificering – “Sustainability Label”

Pågående arbete med hur datacenter skall klassificeras som hållbara. Remiss ute.

## Minimum Performance Standards

Förslag att MPS skall innehålla mål för PUE and WUE. Diskussion kring “neutralisera för geografi”.

Remiss ute.

## Renewable Energy Usage mål?

Diskussion att inkludera REF.

**VAR bör vi etablera datacenter?**



# VAR i världen är det smart att ha datacenter sett ur ett miljöperspektiv?

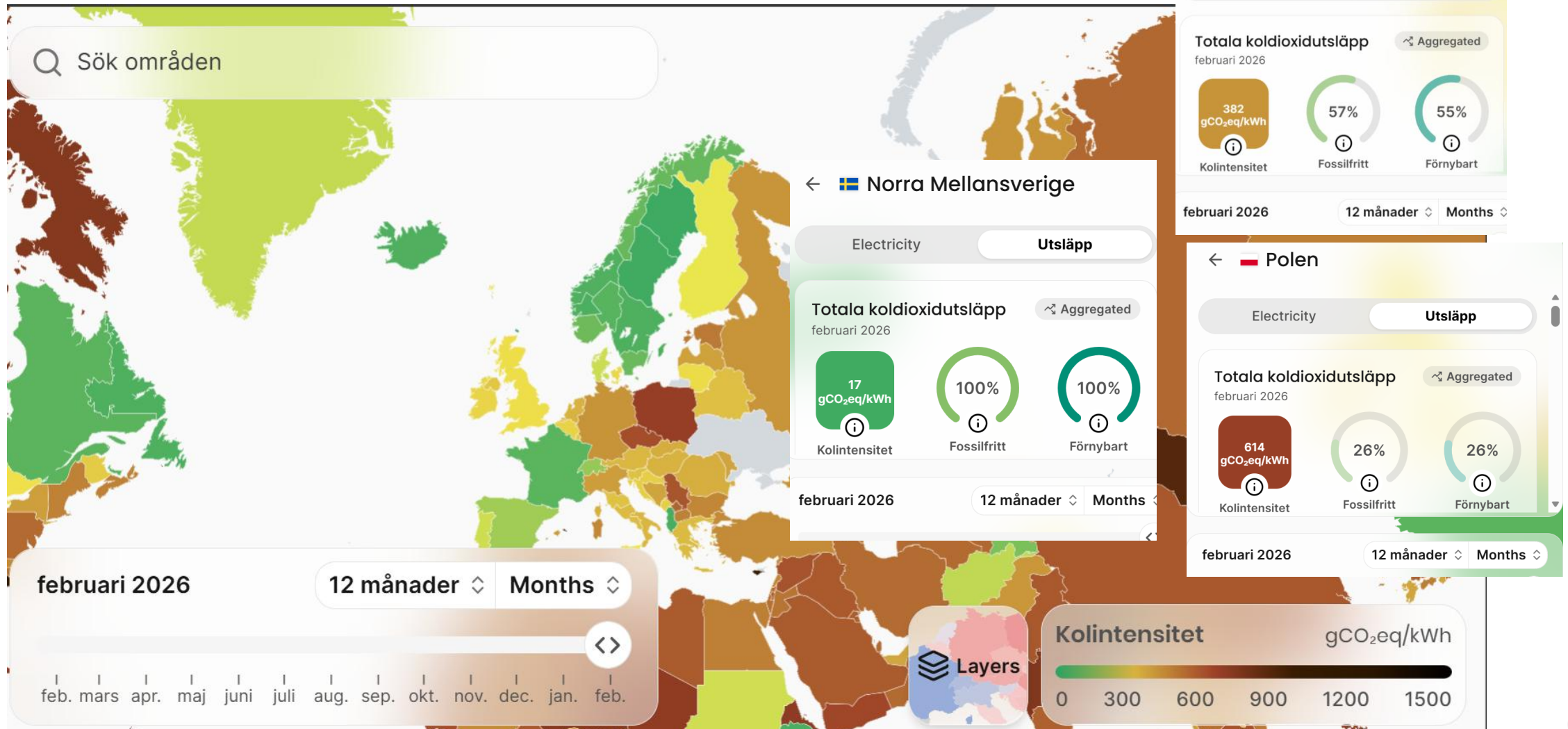

# Stanford University: Vilka delstater har på grundskolenivå ökat fokus på Teknik och Matematik?

## Public high schools teaching foundational CS (% of total in state), 2023

Source: Code.org, 2023 | Chart: 2024 AI Index report

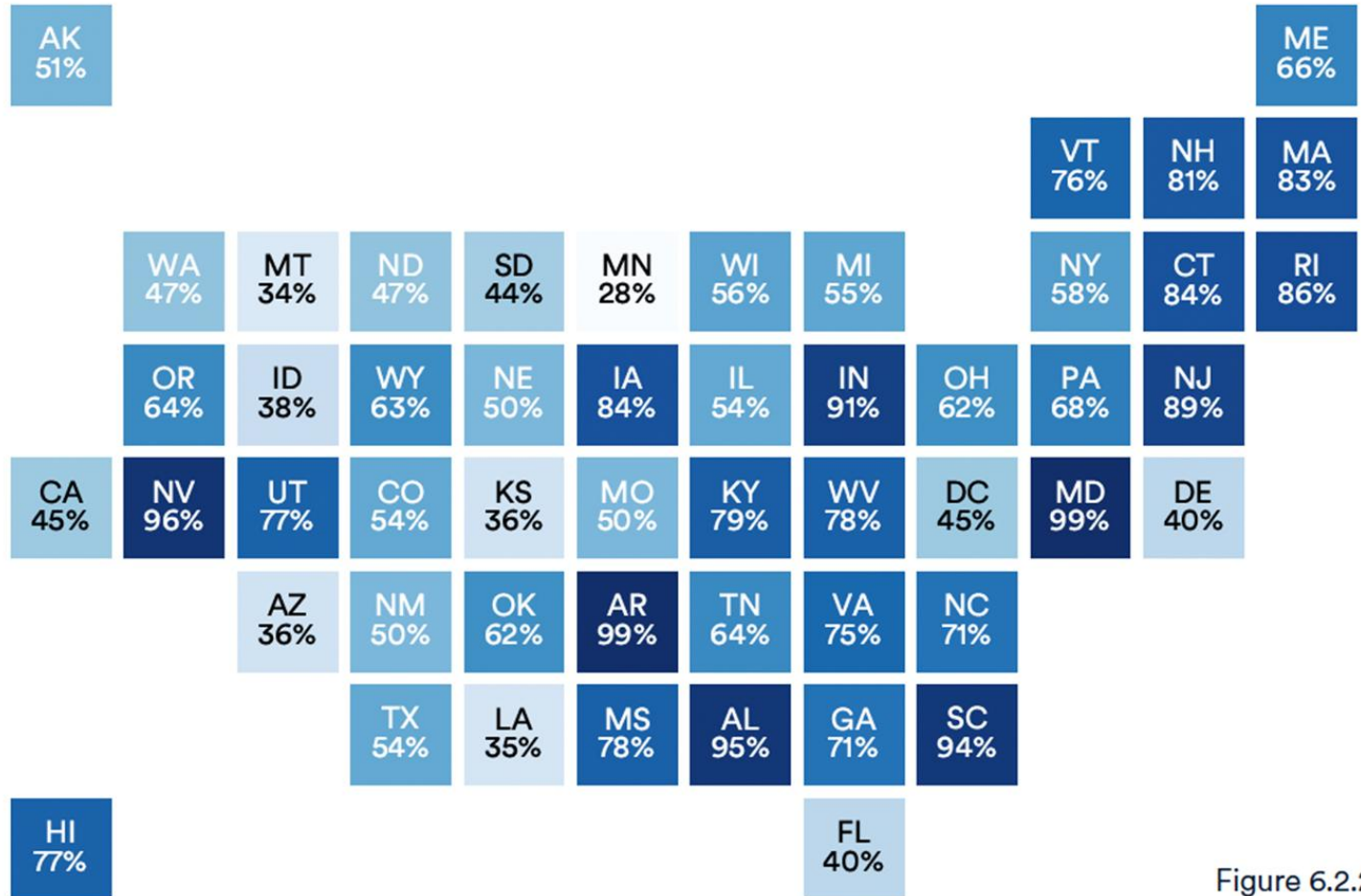

Figure 6.2.2



# Vad kan etableringar av datacenter tillföra Sverige som land?

**Nya arbetstillfällen**

**Regional utveckling**

**Ökad handel**

**Följdetableringar**

**Förutsättningar för digital utveckling**

# Lokal nytta i energi- och industrisystemet med internationellt intresse

## Cirkulär energianvändning med direkt samhällsvärde

- Hundratals byggjobb, ofta med lokala och regionala entreprenörer
- Nya, långsiktiga arbetstillfällen
- EcoDataCenter är integrerat med Faluns lokala energisystem i samarbete med Falu Energi & Vatten
- Restvärme från datacentret återanvänds och bidrar till fjärrvärmepellets, produktion och industriella processer
- Modellen stärker Faluns position som föregångare globalt inom cirkulär och industriellt integrerad digital infrastruktur
- Attraktivitet, innovation och internationell synlighet - **Detta är ett av världens mest uppmärksammade exempel på hållbar datacenterintegration.**

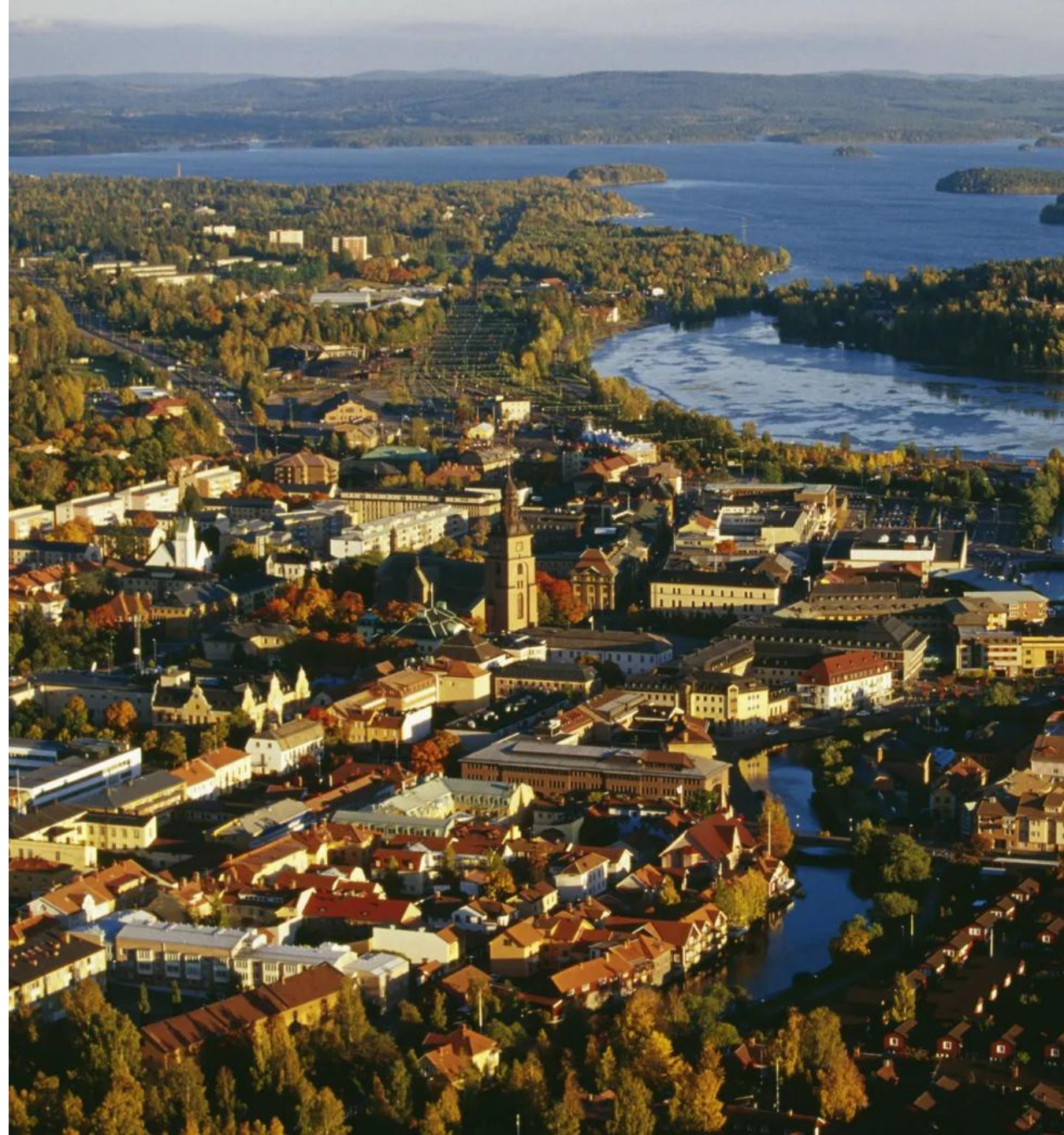

# Sammanfattning

- Ett hållbart datacenter handlar inte bara om el
- Från luftkylt till vätskekylt
- Värmen återvinns
- Datacenter kan bidra till elsystemet på olika sätt
- Energieffektivitetsdirektivet hjälper till att skapa förutsättningar för hållbara datacenter i hela Europa
- Datacenter skapar ringar på vattnet– OM samarbetet har lokalt stöd och vilja!
- Datacenter är en grundförutsättning för Sveriges digitalisering och tillväxt



RI.  
SE

Tack!

Frågor?

**LUNCH**

**Återstart 12.15**